

INSTRUCTION MANUAL

Serial Number _____

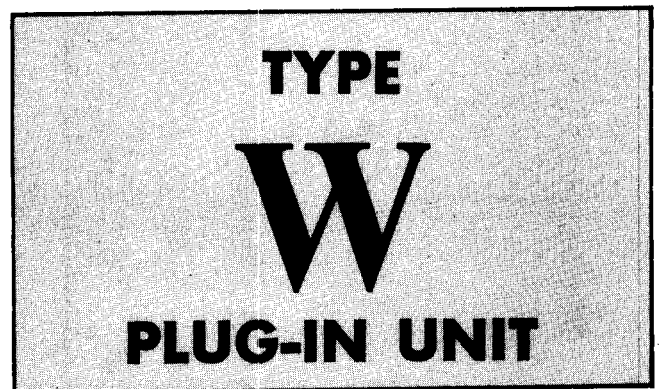

Tektronix, Inc.

S.W. Millikan Way ● P. O. Box 500 ● Beaverton, Oregon 97005 ● Phone 644-0161 ● Cables: Tektronix
070-432

1064



WARRANTY

All Tektronix instruments are warranted against defective materials and workmanship for one year. Tektronix transformers, manufactured in our own plant, are warranted for the life of the instrument.

Any questions with respect to the warranty mentioned above should be taken up with your Tektronix Field Engineer.

Tektronix repair and replacement-part service is geared directly to the field, therefore all requests for repairs and replacement parts should be directed to the Tektronix Field Office or Representative in your area. This procedure will assure you the fastest possible service. Please include the instrument Type and Serial number with all requests for parts or service.

Specifications and price change privileges reserved.

Copyright © 1964 by Tektronix, Inc., Beaverton, Oregon. Printed in the United States of America. All rights reserved. Contents of this publication may not be reproduced in any form without permission of the copyright owner.



CONTENTS

	Warranty
Section 1	Characteristics
Section 2	Operating Instructions
Section 3	Circuit Description
Section 4	Maintenance
Section 5	Calibration
Section 6	Parts List and Diagrams

A list of abbreviations and symbols used in this manual will be found on page 6-1. Change information, if any, is located at the rear of the manual.

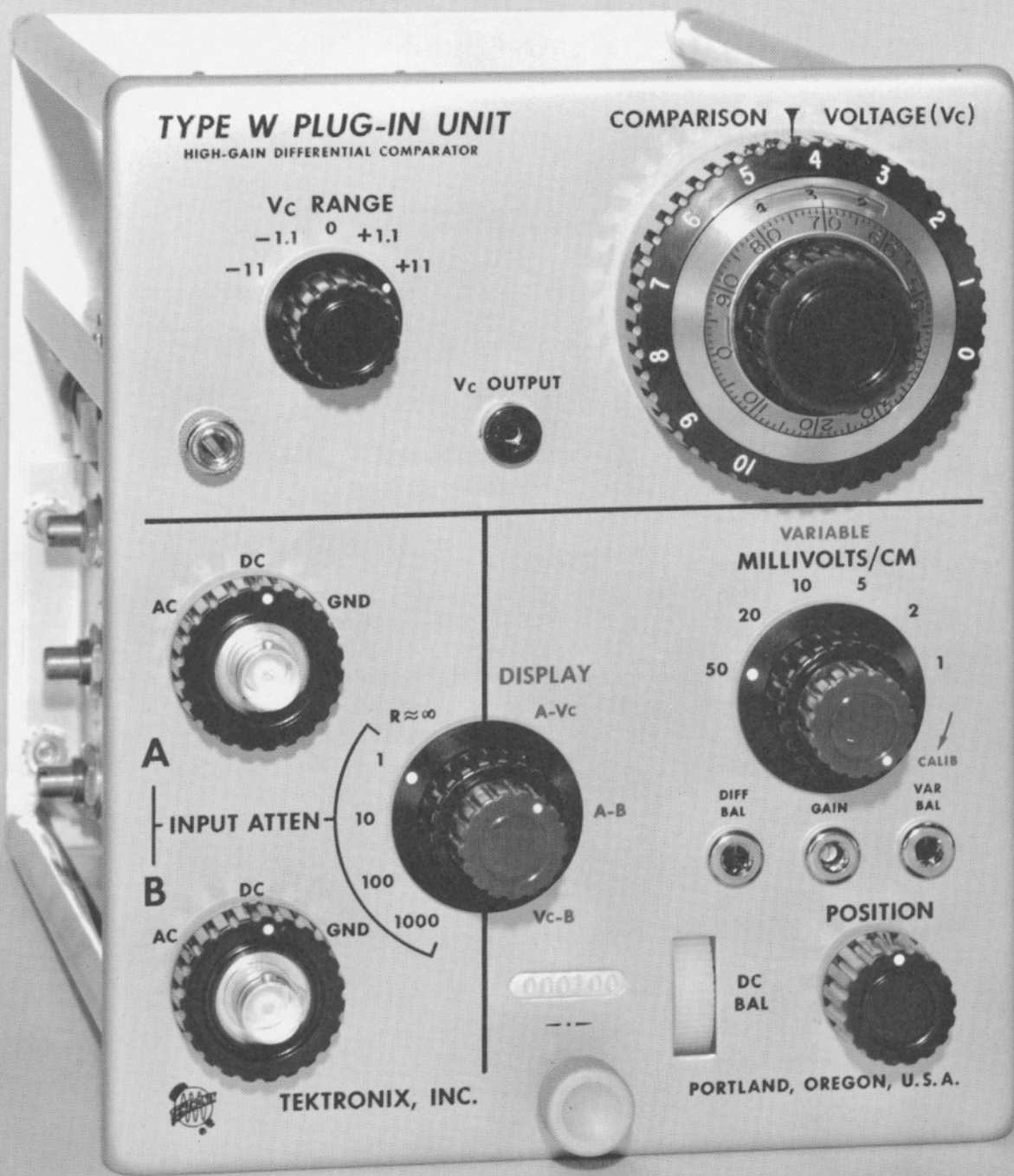

Type W Plug-In Unit

SECTION 1

CHARACTERISTICS

General Information

The Type W Plug-In Unit is a high-gain calibrated differential comparator designed for use in all Tektronix Type 530-, 540-, 550-, and 580-Series Oscilloscopes and their rackmount equivalents. The W Unit can also be used in conjunction with other oscilloscopes and devices through use of the Tektronix Types 127, 132, or 133 plug-in power supplies. The primary operating modes for the unit are: (1) conventional plug-in preamplifier, (2) differential input preamplifier, or (3) differential comparator.

Passband of the W Unit depends upon the oscilloscope used with the unit (see Table 1-1). When the unit is used with a Type 540-Series Oscilloscope at a sensitivity of 1 mv/cm, the maximum passband capability is dc to 8 mc, increasing to dc to 23 mc at 50 mv/cm.

As a differential input preamplifier, the dynamic range of the W Unit permits common-mode signals up to ± 15 volts in amplitude to be applied to the amplifier without attenuation. With a rejection ratio of about 20,000 to 1 for dc or low-frequency signals, small signals of 1 mv or less on large common-mode signals can be measured. Common-mode signals which exceed the dynamic range of the W Unit can be attenuated before being applied to the amplifier by means of an input attenuator.

As a differential comparator, voltage measurements using the slide-back technique can be made with this unit. The high accuracy and stability of the dc comparison voltage added differentially to the input signal makes precise voltage measurements possible. Using this mode of operation, the W Unit has an effective screen height of $\pm 11,000$ cm. This is equivalent to a ± 11 -volt dynamic signal range at a maximum sensitivity of 1 mv/cm. Within this range, calibrated \pm dc comparison voltages can be added differentially to the input signal to permit a maximum of about 0.001% or 100 μ v per mm to be resolved.

AS A CONVENTIONAL PREAMPLIFIER

Sensitivity

The MILLIVOLTS/CM switch has six calibrated positions: 1, 2, 5, 10, 20, and 50 mv/cm. In addition, a variable (uncalibrated) control provides for continuously-variable adjustment between steps and up to about 125 mv/cm.

Calibration Accuracy

An adjustment is provided for setting the gain of the unit. When this adjustment is accurately set with the MILLIVOLTS/CM switch in the 50 mv/cm position, the vertical sensitivity for any other position of the switch will be within 3% of the panel reading for that position.

Input Impedance

For the 1X, 10X, 100X, and 1000X positions of the INPUT ATTEN switch, input impedance is 1 megohm paralleled by

20 pf (nominal). 1X input resistance matches the 10X input resistance within $\pm 0.1\%$. For the $R \approx \infty$ position input resistance is on the order of 10,000 to 50,000 megohms paralleled by about 19 pf.

Passband

TABLE 1-1
Approximate Passband
(Source impedance: 25 ohms)

W Unit and Type ¹ :	Passband ²					
	MILLIVOLTS/CM at:					
	50	20	10	5	2	1
547, 546, 544, 581 ³ , 581A ³ , 585 ³ , 585A ³ , 541 541A, 543, 543A, 543B, 545, 545A, 545B, 555	23	22	21	16	13	8
551	20.5	19.8	19	15	12.5	8
531, 531A, 533, 533A, 535, 535A	13.5	13.5	13.3	11.8	10	7
536	10.5	10.5	10.5	9.7	9	6.5
127 (output terminated into 170 ohms)	16.5	16	15.5	13.5	11	7.5
132 (output terminated into 93 ohms)	14.5	14.5	14	11	10.5	7
133	100 kc					

¹ Table 1-1 also applies to rackmount equivalents of the oscilloscope listed.

² Passband in Megacycles per Second (for signals that do not overscan the crt screen): Dc to 30% down point using dc coupling; for ac coupling the low-frequency 30% down point is 2 cps, the high-frequency 30% down point is the same as shown in the table.

³ Type 81 Plug-In Adapter must be used with 580-series oscilloscopes.

Input Attenuation Accuracy

See Table 1-2.

TABLE 1-2

INPUT ATTEN Switch Position	Attenuation Accuracy
10X	$\pm 0.05\%$
100X	$\pm 0.15\%$
1000X	$\pm 3\%$

Maximum Allowable Input Voltage Rating

See Table 1-3.

Characteristics—Type W

TABLE 1-3

INPUT ATTEN Switch Position	Maximum Input Voltage	
	Combined DC and Peak AC (DC coupled)	Peak AC (AC coupled)
R \approx ∞ and 1X	± 15 v	15 v
10X	± 150 v	150 v
100X, 1000X	± 500 v	500 v

AS A DIFFERENTIAL INPUT PREAMPLIFIER

Maximum Common-mode Signal Amplitude

See Table 1-3.

Common-mode Rejection Ratio

See Table 1-4.

TABLE 1-4

Common-mode Signal	Method of Coupling	Minimum Common-mode Rejection Ratio
DC ¹	DC	20,000 to 1
60 cps ²	AC	1,000 to 1
20 kc ³	DC	20,000 to 1
500 kc ³	DC	500 to 1

¹ DC common-mode rejection ratio is measured with the W Unit set for 1 mv/cm sensitivity. First, the trace is centered, both AC-DC-GND switches are set to GND, and the mode of operation is A-B. Then the comparison voltage is set for +10 volts output and applied to both inputs. Both AC-DC-GND switches are set to DC. The indicated voltage (trace shift X MILLIVOLTS/CM switch setting) is then measured. Next, a comparison voltage of -10 volts is applied to both inputs and the indicated voltage is measured once again. Rejection ratio is the applied voltage divided by the indicated voltage.

² Signal amplitude of 20 volts peak-to-peak is ac-coupled to both inputs. W Unit sensitivity is set to 1 mv and mode is A-B. Rejection Ratio is the peak-to-peak input signal amplitude divided by the displayed signal peak-to-peak amplitude.

³ Signal amplitude of 20 volts peak-to-peak is dc-coupled to both inputs. Rejection ratio is then measured the same as described for footnote ².

AS A CALIBRATED DIFFERENTIAL COMPARATOR

Comparison Voltages

Two voltage ranges are provided: from zero to ± 1.1 volt, and from zero to ± 11 volts. The Vc RANGE switch selects the range; a second switch selects the first digit;

and a precision 10-turn potentiometer selects the remaining digits.

Comparison Voltage Accuracy and Drift

Within $\pm(0.15\%$ of indicated value + 0.05% of full scale).

Measurement Resolution

Resolution is 100 μ volts per mm at maximum sensitivity.

Maximum Input Grid Current

2 nanoamperes maximum; typically less than 1 nanoampere.

Overdrive Recovery

Application of an input signal of sufficient amplitude to drive the trace off the crt screen may overdrive the amplifier in the W Unit.

After being overdriven, the amplifier will recover to within 10 mv of the reference level (referred to the comparison voltage) within 300 nsec. Certain overdrive signals may cause an additional slow (thermal) shift in the reference level of up to 5 mv.

Input Attenuator Accuracy

Attenuation accuracy is within the tolerances specified in Table 1-2.

Environment

Storage: -40° C to $+65^{\circ}$ C, to 50,000 ft.

Operating Temperature: 0° C to $+50^{\circ}$ C.

Operating Altitude: To 15,000 ft.

OTHER CHARACTERISTICS

Mechanical Specifications

Construction: Aluminum-alloy chassis.

Accessories

Information on accessories for use with this instrument is included at the rear of the mechanical parts list.

SECTION 2

OPERATING INSTRUCTIONS

Front Panel

A front-panel view of the Type W Unit is shown in Fig. 2-1. In addition, a brief functional description is given of the front-panel controls, input connectors, and securing rod.

Connecting the W Unit to the Oscilloscope

Connect the W Unit to the associated oscilloscope as follows:

NOTE

To provide the best possible turn-on conditions for the unit, make sure the oscilloscope power is off before inserting the unit in the compartment. Thus, circuit protection provided by the oscilloscope time-delay relay will be fully utilized.

1. Insert the unit into the plug-in compartment and tighten the W Unit securing rod.

2. Set the W Unit front-panel controls as follows:

Vc RANGE	As is
COMPARISON VOLTAGE	As is
AC-DC-GND (both inputs)	GND
INPUT ATTEN	1
DISPLAY	A-B
MILLIVOLTS/CM	50
VARIABLE	CALIB
POSITION	Midrange

3. With the Intensity control of the oscilloscope turned fully counterclockwise, switch on the oscilloscope power.

4. Wait a few minutes for the oscilloscope and plug-in to warm up and stabilize.

5. Turn up the intensity and set the oscilloscope triggering controls to produce a free-running sweep. The trace should appear near graticule center on the crt.

NOTE

If the trace is not near center or is off the crt, first check the DC BAL and VAR BAL adjustments by following the procedures described next.

Preliminary Operational Adjustments

After the unit has warmed up and stabilized, check its operation to see if adjustment of one or more of the following controls is necessary. Be sure that the oscilloscope used in conjunction with the W Unit is correctly calibrated in the vertical-deflection circuit, and that the calibrator output voltage is correct. In the Amplifier DC Balance and Variable Balance procedures that follow, the procedures assume that the W Unit is being used for the first time. Once these ad-

justments are made, the DC BAL is the only adjustment that needs occasional "touching up" during normal use of the unit.

1. Amplifier DC Balance

Any vertical shift of the trace when the VARIABLE control is rotated with the AC-DC-GND switches set to GND, indicates need for adjusting the DC BAL control (see Fig. 2-1). To make this adjustment, proceed as follows:

a. First, set the front-panel controls to the same positions as listed in the preceding topic titled, "Connecting the W Unit to the Oscilloscope".

b. Adjust the DC BAL control to eliminate any vertical shift of the trace as the VARIABLE control is rotated back and forth.

c. Set the MILLIVOLTS/CM switch to 5. If the trace is off the crt, adjust the VAR BAL control (see Fig. 2-1) to position the trace near the center of the crt.

d. Repeat step 1b.

e. Set the MILLIVOLTS/CM switch to 1. If the trace is off the crt, adjust the VAR BAL control to position the trace near the center of the crt.

f. Repeat step 1b. While repeating step 1b, keep the trace centered by adjusting the VAR BAL control since there is interaction between this control and the DC BAL control.

NOTE

Once the DC BAL and VAR BAL (next step) controls are initially adjusted, only the DC BAL control need be adjusted occasionally to minimize trace shift as either the VARIABLE or MILLIVOLTS/CM control is rotated. This also applies when the W Unit is transferred from one oscilloscope to another.

2. Variable Balance

If the trace shifts as the MILLIVOLTS/CM switch is moved from one position to the next through all its positions, this indicates that the VAR BAL adjustment needs to be checked. Since this adjustment interacts with the DC BAL control, perform step 1 "Amplifier DC Balance" adjustment procedure first if you have not already done so. Leave the controls as they are upon completing step 1 and then proceed as follows:

a. Adjust the VAR BAL control to minimize any vertical shift of the trace as the MILLIVOLTS/CM switch is switched from the 1 to the other positions and back again. Repeat this procedure as often as is necessary to minimize the trace shift.

b. Repeat step 1b in the "Amplifier DC Balance" procedure and 2a in this procedure as often as necessary to minimize trace shift.

SECTION 2

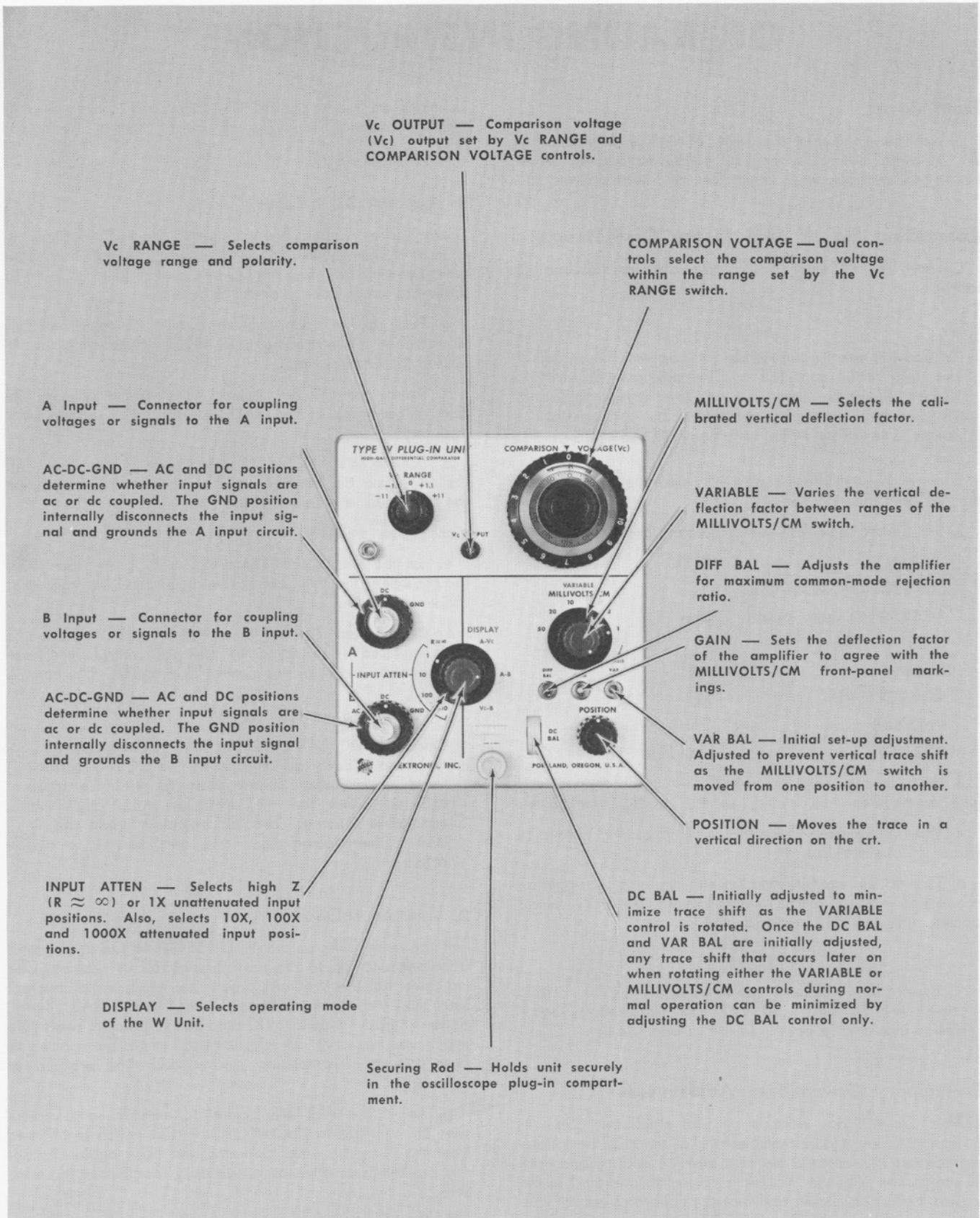

Fig. 2-1. Functions of front-panel controls, input connectors, and Securing Rod.

NOTE

Once the VAR BAL control is adjusted as desired, it ordinarily does not require readjustment. Any trace shift that results from rotating the VARIABLE or MILLIVOLTS/CM controls during normal use of the W Unit can be minimized by adjusting the DC BAL control.

3. Gain

The GAIN adjustment (see Fig. 2-1) should be checked periodically to assure correct vertical deflection factors. The adjustment can be made using the oscilloscope calibrator as the signal source. If greater accuracy is needed, a signal source with more precise amplitude accuracy can be used.

a. Set the front-panel controls as follows.

AC-DC-GND (A)	DC
AC-DC-GND (B)	GND
INPUT ATTEN	1
DISPLAY	A-B
MILLIVOLTS/CM	50
VARIABLE	CALIB

b. Apply a 0.2-volt peak-to-peak calibrator signal through a coaxial cable to the A input connector.

c. Using the POSITION control, position the display to the center of the crt viewing area. Set the oscilloscope controls to display several cycles of the waveform.

d. Adjust the GAIN control to obtain exactly 4 centimeters of vertical deflection.

4. Differential Balance

Differential balance may be quickly checked in the following manner.

a. Set the front-panel controls as follows:

AC-DC-GND (A and B)	DC
INPUT ATTEN	1
DISPLAY	A-B
MILLIVOLTS/CM	1
VARIABLE	CALIB
POSITION	Midrange

b. Apply 10 volts of calibrator signal through a T connector and coaxial cables to both A and B input connectors.

c. Ignoring the positive and negative spikes, adjust the DIFF BAL control (see Fig. 2-1) to eliminate any square-wave response; that is, to obtain a straight-line appearance of the trace.

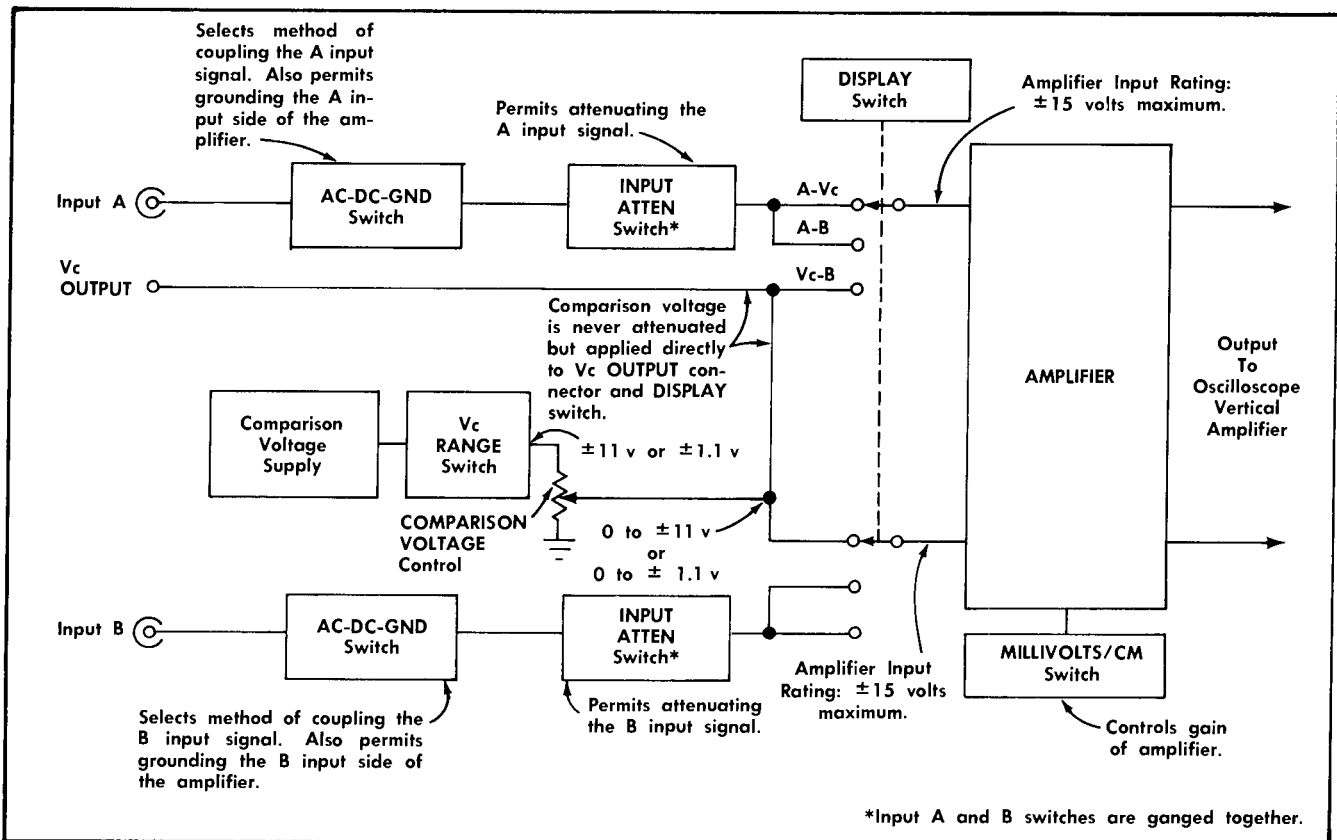

Fig. 2-2. Simplified block diagram showing DISPLAY switch positions and Vc OUTPUT connection.

Operating Instructions—Type W

Block Diagram

The simplified block diagram shown in Fig. 2-2 is useful for studying the electrical location of the AC-DC-GND, INPUT ATTEN, COMPARISON VOLTAGE, and MILLIVOLTS/CM controls. Particularly, the diagram shows where the INPUT ATTEN switches are located with respect to the location of the MILLIVOLTS/CM switch and the COMPARISON VOLTAGE control.

When a signal is applied to the W Unit input connector, attenuation of the signal takes place in the INPUT ATTEN switch before the signal is applied through the DISPLAY switch to the amplifier. The INPUT ATTEN switch does not attenuate the comparison voltage because the comparison voltage is applied separately through the DISPLAY switch (in the A-Vc or Vc-B positions) directly to the input of the amplifier.

It is also important to note that there are two ways to obtain the same sensitivity when using the INPUT ATTEN and MILLIVOLTS/CM switches. One way gives more bandwidth; the other way gives less bandwidth but greater slide-back voltage capabilities. The following methods show two ways to get 10 mv/cm sensitivity. Also, for explanation purposes, assume the W Unit is used with the Type 540-series oscilloscope.

Method 1:

Set the INPUT ATTEN switch to 1 and the MILLIVOLTS/CM switch to 10. This gives a bandwidth of 21 mc for signals that do not overscan the screen. If the W Unit is used as a differential comparator to null out a dc or low-frequency ac component of a signal, the maximum slide-back comparison voltage is 11 volts. For example, if 10 volts were applied to the W Unit, 10 volts of comparison voltage is needed to null the 10 volts of applied voltage.

Method 2:

Set the INPUT ATTEN switch to 10 and the MILLIVOLTS/CM switch to 1. This gives a bandwidth of only 8 mc (for signals that do not overscan the screen) and a slightly noisy trace. However, when using differential-comparator mode of operation to null out a dc or low-frequency component of a signal, the true slide-back voltage is 10X greater using this method rather than Method 1. For example, if 10 volts were applied to the W Unit, the INPUT ATTEN switch attenuates the 10 volts to 1 volt using Method 2 and a comparison voltage of only 1 volt is all that is needed to null the 10 volts of applied voltage. Thus, the 1 volt of comparison voltage is really equal to 10 volts since it nulls the 10-volt applied voltage.

Using differential-comparator operation and Method 2 (for example), 110 volts maximum can be applied to the W Unit because the INPUT ATTEN switch setting at 10 attenuates the 110 volts to 11 volts before the voltage is applied to the amplifier. The 11 volts is within the ± 15 -volt rating of the amplifier input stage and can be nulled by the 11-volt maximum comparison voltage available in the unit. The COMPARISON VOLTAGE control dial indication is not affected by the setting of the MILLIVOLTS/CM switch because the MILLIVOLTS/CM switch acts as null resolution or null

sensitivity control. True comparison voltage using either method is determined by using this formula:

$$\begin{array}{rcccl} \text{True} & & \text{COMPARISON} & & \text{INPUT} \\ \text{Comparison} & = & \text{VOLTAGE} & & \text{ATTEN} \\ \text{Voltage} & & \text{Control} & \times & \text{Switch} \\ & & \text{Reading in} & & \text{Position:} \\ & & \text{Volts} & & \text{1, 10, 100,} \\ & & & & \text{or 1000} \end{array} \quad \times \quad \begin{array}{l} \text{Probe} \\ \text{Attenuation} \\ \text{Factor} \end{array}$$

Input Signal Connections

Before connecting signals to the A and/or B connectors on the W Unit, consider the method of coupling that will be used. Table 2-1 lists a choice of seven different methods. For each method the table lists the advantages, limitations, accessories required, source loading and precautions to consider. Check through the table and select the method which is suitable for your particular application.

Use of Probes

Attenuator probes reduce loading of the signal source. However, in addition to providing isolation of the oscilloscope from the signal source, an attenuator probe also decreases the amplitude of the displayed waveform by the attenuation factor of the probe. When making amplitude measurements with an attenuator probe, be sure to multiply the observed amplitude by the attenuation of the probe.

An adjustable capacitor in the probe body compensates for variations in input capacitance from one plug-in unit to another. To assure the accuracy of pulse and transient measurements, this adjustment should be checked frequently. To make this adjustment, proceed as follows:

1. Set the oscilloscope Amplitude Calibrator for an output of suitable amplitude.
2. Place the DISPLAY switch to the A-B position.
3. Set the AC-DC-GND switch to DC for the input in use. Set the unused input AC-DC-GND switch to GND.
4. Touch the probe tip to the calibrator output connector and adjust the oscilloscope controls to display several cycles of the waveform.
5. Adjust the probe compensation for best square-wave response.

NOTE

If a square-wave source other than the oscilloscope calibrator is used for compensating the probe do not use a repetition rate higher than 5 kc. At higher repetition rates, the waveform amplitude appears to change as the probe is compensated. Thus, proper compensation is difficult to attain. If the probe remains improperly compensated, transient and frequency response of the system will be poor and measurements will be inaccurate.

TABLE 2-1
Signal Coupling Methods

Method of Coupling the Signal	Advantages	Limitations	Accessories Required	Source Loading*	Precautions
1. Open (unshielded) test leads.	Simplicity.	Limited frequency response. Subject to stray pickup.	BNC to Banana Jack adapter (103-033). Two test leads.	1 Meg Ω and 20 pf at input, plus test leads.	Stray pickup and spurious oscillations. Insert series 47-ohm resistor.
2. Unterminated coax cable.	Full sensitivity.	Limited frequency response. High capacitance of cable.	Coax cable with BNC connector(s).	1 Meg Ω and 20 pf plus cable capacitance.	High capacitance loading.
3. Terminated coax cable. Termination at Type W input.	Full sensitivity. Total Type W/Oscilloscope bandwidth. Relatively flat resistive loading. Long cable with uniform response.	Presents R_0 (typically 50 Ω) loading at end of coax. May need blocking capacitor to prevent dc loading or damage to termination.	Coax cable with BNC connector(s). R_0 termination at Type W input. (BNC 50 Ω Termination, 011-049).	R_0 plus 20 pf at Type W end of coax can cause reflections.	Reflection from 20 pf at input. Dc and ac loading on test point. Power limit of termination.
4. Same as 3, with coaxial attenuator at termination.	Less reflection from 20 pf at termination.	Sensitivity is reduced (increased Deflection Factor).	BNC Coaxial attenuators.	R_0 only.	Dc and ac loading on test point. Power limit of attenuator.
5. Tap into terminated coax system. (BNC T: UG-274/U at Type W input.	Permits signal to go to normal load. Dc or ac coupling without coaxial attenuators.	20 pf load at tap point	BNC T and BNC connectors on signal cables.	1 Meg Ω and 20 pf at tap point.	Reflections from 20 pf input.
6. 10X, 10 Meg Ω Probe. 100X, 9.1 Meg Ω Probe. 1000X, 100 Meg Ω Probe.	Reduced resistive and capacitive loading, nearly full Type W/Oscilloscope bandwidth (21 mc) using P6023 probe; full bandwidth using the other probe types.	X0.1 sensitivity. X0.01 sensitivity. X0.001 sensitivity.	P6023 is 10X; P6007 is 100X; P6015 is 1000X.	P6023: \approx 12 pf, 8 Meg Ω P6007: \approx 2.3 pf, 10 Meg Ω P6015: \approx 3 pf, 100 Meg Ω	Check probe frequency compensation. Use square-wave frequency less than 5 kc, preferable 1 kc.
7. Current transformer. Terminated in 50 Ω at Type W. Bandwidth that of Type W/Oscilloscope.	Current xfmr can be permanent part of test circuit. Less than 2.2 pf to test circuit chassis. Measure signal currents in transistor circuits. CT-1: 20 amps pk CT-2: 100 amps pk	Rms current rating: CT-1: 0.5 amp CT-2: 2.5 amps Sensitivity: CT-1: 5 mv/ma CT-2: 1 mv/ma	CT-1: Coax adapter and BNC termination. CT-2: nothing extra. (Perhaps additional coax cable for either transformer.)	CT-1: Insertion; 1 Ω paralleled by about 5 μ h. Up to 1.5 pf. CT-2: Insertion; 0.04 Ω paralleled by about 5 μ h. Up to 2.2 pf.	Not a quick-connect device. CT-1: low frequency limit about 75 kc. CT-2: low frequency limit about 1.2 kc, and is 1/5th as sensitive as the CT-1.

*Applies to 1, 10, 100, and 1000 positions of the INPUT ATTEN switch.

Conventional Preamp Operation

When the W Unit is used as a conventional preamplifier, there are two ways to set up the controls. Either the A or B input can be used, but for explanation purposes assume that the signal is to be applied to the A input to obtain an upright display (see Fig. 2-3). One way to set up the controls is as follows:

- a. Set the DISPLAY switch to A-B.
- b. Apply the signal to input A.

c. Set input A AC-DC-GND switch to AC or DC, depending on the method of signal coupling desired.

d. Set input B AC-DC-GND switch to GND.

The other method is as follows:

- a. Set the DISPLAY switch to A-Vc and the Vc RANGE switch to 0.
- b. Apply the signal to input A.

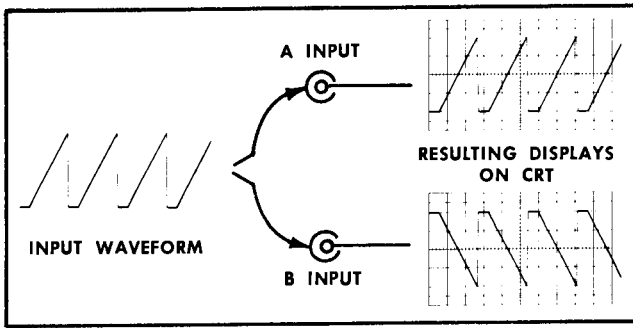

Fig. 2-3. Waveforms applied to the A input connector produce an upright display, while waveforms applied to the B input are inverted.

c. Set input A AC-DC-GND switch to AC or DC, depending on the method of signal coupling desired. The B input AC-DC-GND switch can be left in any position.

Operation of the unit if input B was used instead of input A and the controls were set to their appropriate positions is essentially the same except that signals applied to the B input connector are inverted on the display. Positive voltages produce an upward deflection when applied to the A connector and a downward deflection when applied to the B connector (see Fig. 2-3).

The amount of vertical deflection produced by a signal is determined by the settings of the INPUT ATTEN, MILLIVOLTS/CM, and VARIABLE controls. Calibrated deflection factors indicated by the MILLIVOLTS/CM switch apply only when the VARIABLE control is set to the CALIB detent position. Serious errors in display measurements may result if the setting of this control is inadvertently moved away from the CALIB position.

The range of the VARIABLE control is about 2.5 to 1 with respect to the calibrated level to provide continuously variable (uncalibrated) vertical-deflection factors between calibrated settings of the MILLIVOLTS/CM switches. As the control is rotated a few degrees counterclockwise from the CALIB position, a switch is actuated which increases the gain about 10%. This increase provides overlapping coverage between calibrated steps.

Voltage measurements in millivolts may be made directly from the crt by noting the amount of vertical deflection on the crt. Then multiply the deflection on the crt by the setting of the MILLIVOLTS/CM switch, the INPUT ATTEN switch, and attenuation factor, if any, of the probe.

Placing the AC-DC-GND switch in the AC position inserts a dc blocking capacitor in series with the input circuit. In the AC position the input time constant is 0.1 second and the low-frequency response is 2 cps at 30% down. Thus, some attenuation exists even at 60 cps. Two principle occasions where ac coupling is used are:

1. When it is desired to get a quick look at the ac component of a signal which has a large dc component.
2. To measure the peak-to-peak voltage of the ac component while blocking the dc component.

In the DC position of the AC-DC-GND switch, both the ac and dc components of an applied signal can be observed. This position is useful for measuring dc levels of voltages or for measuring the instantaneous dc level at a given point on a waveform.

The GND position of the AC-DC-GND switch allows the signal to be disconnected from the W Unit amplifier input without having to physically disconnect the applied signal externally. This position provides an easy method for determining the zero dc reference of the trace. However, this method does not take into account trace deviation from exact zero due to ground-loop and grid currents. If these voltages are significant and utmost measurement accuracy is desired, touch the probe tip to the point you wish to use as the reference instead of setting the AC-DC-GND switch to GND.

Differential Preamplifier Operation

The primary purpose of differential operation is to eliminate undesirable common-mode signals. The term "common-mode signal" is defined as that signal which is common to both inputs of a differential amplifier. It usually, but not necessarily, represents unwanted hum or noise.

This mode of operation can be used, for example, to observe the signal across one circuit element while effectively eliminating the remainder of the circuit from the observations. This is accomplished by connecting the signal at one end of the element to one input of the W Unit and the signal at the other end of the element to the other input of the unit.

Differential operation between the two inputs is obtained by setting the DISPLAY switch to A-B and both AC-DC-GND switches to the same AC or DC positions, depending on the method of coupling desired. For low frequencies, maximum common-mode rejection ratio is obtained when the AC-DC-GND switches are set to DC and MILLIVOLTS/CM switch is set to 1. The VARIABLE control should be set to CALIB.

Differential or common-mode rejection ratio is a function of frequency in practical amplifiers. It is 20,000 to 1 for dc common-mode signals in the W Unit and remains near that value through audio frequencies, decreasing as the frequency increases.

The common-mode rejection ratio of the W Unit describes the ability of the unit to reject common-mode signals. This ratio can also be defined as the ratio of amplifier response to that part of the input signal not common to both inputs, with respect to the response of the amplifier to any input signal which is common to both inputs. It can be shown numerically by using the following example.

If an input signal consists of 10 volts (peak-to-peak) of 60-cps hum and 5 millivolts of desired signal, the 10-volt hum would cause 10 volts divided by 1 mv/cm or 10,000 cm of deflection at maximum sensitivity using conventional preamplifier mode of operation. The 5-millivolt signal will produce 5 cm of deflection "superimposed" on the 10,000-cm waveform. Using conventional preamplifier operation, the desired signal would be deflected off the crt and could

not be observed. However, by using dc-coupled differential operation at a ratio of 20,000 to 1, the hum can be differentially suppressed to an amplitude of 0.5 mv and this would cause a deflection of only 0.5 cm or less on the 5-cm desired signal. Thus, by suppressing the hum the desired signal can be easily observed and measured.

The preceding example is shown in the series of waveform photographs shown in Fig. 2-4. A combined 10-volt hum and 5-millivolt square-wave signal is shown in Fig. 2-4(a). Although the square-wave signal does not seem to be present, it can be seen by increasing the sensitivity of the W Unit to 2 mv/cm, which increases the effective height of the waveform so it produces a deflection of 5,000 cm on the crt. To view the top portion of this waveform, a dc comparison voltage (using differential comparator operation explained later in this section) of approximately 5 volts is used to bring the top portion of the combined signals into view as shown by the waveform photograph in Fig. 2-4(b). The square-wave signal, "superimposed" on the hum but not synchronized with it, causes the double appearance of the waveform.

A 10-volt peak-to-peak hum signal is applied to input B. This signal is actually in phase with the A-input hum signal but is inverted as it passes through the W Unit amplifier as shown in Fig. 2-4(c). The B input signal differentially suppresses the hum portion of the signal applied to input A. The resulting display using A-B differential preamplifier operation is shown in Fig. 2-4(d).

The following five operational notes provide helpful information to obtain optimum performance from the W Unit when using differential mode of operation.

1. Large signal handling capabilities of the W Unit as a differential amplifier are shown in Table 2-2.
2. Both AC-DC-GND switches should be in the DC position, if possible, to obtain best common-mode rejection at the lower frequencies (below 20 kc).
3. Differential rejection ratio may decrease slightly as the VARIABLE control is rotated away from the CALIB position.

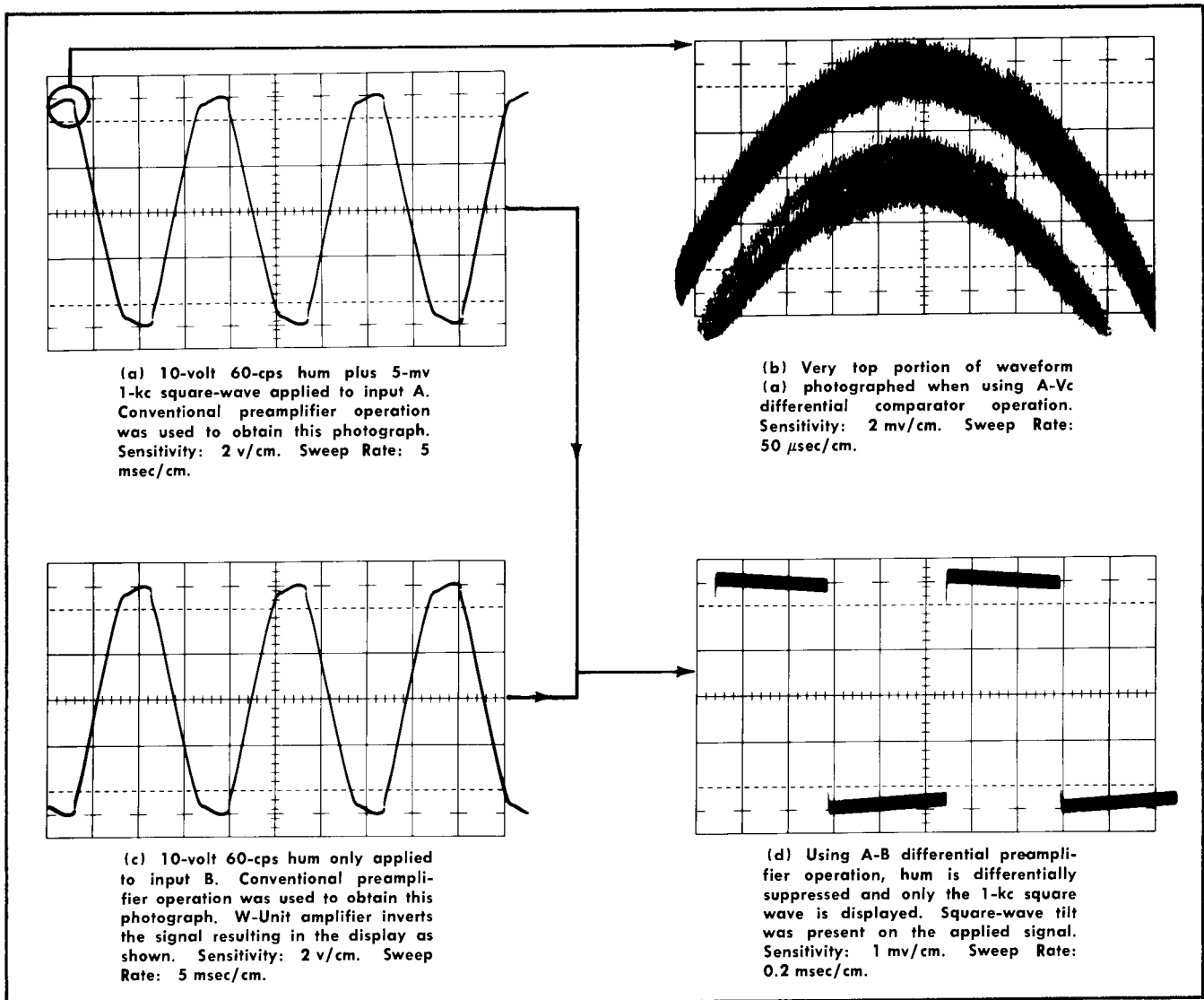

Fig. 2-4. Common-mode rejection by the W Unit.

Operating Instructions—Type W

4. Either input signal alone may be viewed by setting the AC-DC-GND switch for one of the inputs to GND. Then, set the INPUT ATTEN and MILLIVOLTS/CM switches to positions that will attenuate the signal sufficiently so the entire peak-to-peak amplitude of the waveform can be viewed within the graticule area.

5. If conventional passive attenuator probes are used, consider that the probe resistor tolerance is about 1%. If the tolerance between the probes is in opposite directions, this difference will decrease the attenuation accuracy and hence the differential capabilities of the W Unit. To avoid this, use the Type P6023 Probe. This probe can be adjusted to compensate for the slight differences.

Calibrated Differential Comparator Operation

When the DISPLAY switch is in the A-Vc or Vc-B position and the Vc RANGE switch is set to one of the + or - voltage ranges, the W Unit operates as a calibrated differential comparator or slide-back voltmeter. The calibrated comparison voltage, which has a range of 0 to 11 volts, may be

added (differentially) to either input signal to obtain a null. Table 2-3 shows the maximum signal that can be nulled using the 1, 10, 100, and 1000 positions of the INPUT ATTEN switch.

TABLE 2-3

Maximum Signal*	INPUT ATTEN Switch Position
11	1
110	10
500**	100 or 1000

*Maximum dc, dc and peak ac, or peak-to-peak ac signal in volts that can be nulled using up to 11 volts comparison voltage available in the W Unit.

**Maximum input voltage rating of the W Unit.

In this mode of operation a calibrated dc comparison voltage is internally applied to differentially offset any unwanted portion or component of the applied signal, thereby allowing accurate measurements of relatively small ac or dc signals riding on top of relatively large ac or dc signals.

TABLE 2-2

Signal Handling Capabilities of the W Unit

Maximum Signal (peak-to-peak volts)*	INPUT ATTEN Switch Setting	MILLIVOLTS/CM Switch Setting	Magnification Factor**	True Deflection Factor***
15	1	1	15,000×	1 mv/cm
15	1	2	7,500×	2 mv/cm
15	1	5	3,000×	5 mv/cm
15	1	10	1,500×	10 mv/cm
15	1	20	750×	20 mv/cm
15	1	50	300×	50 mv/cm
150	10	1	15,000×	10 mv/cm
150	10	2	7,500×	20 mv/cm
150	10	5	3,000×	50 mv/cm
150	10	10	1,500×	0.1 v/cm
150	10	20	750×	0.2 v/cm
150	10	50	300×	0.5 v/cm
500	100	1	5,000×	0.1 v/cm
500	100	2	2,500×	0.2 v/cm
500	100	5	1,000×	0.5 v/cm
500	100	10	500×	1 v/cm
500	100	20	250×	2 v/cm
500	100	50	100×	5 v/cm
500	1000	1	500×	1 v/cm
500	1000	2	250×	2 v/cm
500	1000	5	100×	5 v/cm
500	1000	10	50×	10 v/cm
500	1000	20	25×	20 v/cm
500	1000	50	10×	50 v/cm

*Maximum signal that can be applied to each input when the INPUT ATTEN switch is set to the position indicated in the second column.

**If a common-mode signal applied to both inputs could be viewed separately in its entirety, the display amplitude would be the same as the magnification factor in cm.

***VARIABLE (MILLIVOLTS/CM) control set to CALIB.

When the DISPLAY switch is in the A-Vc position, the comparison voltage is applied internally to the amplifier input where the B signal is ordinarily applied during differential mode of operation. The AC-DC-GND switch in the B section is not used (see Fig. 2-2). Thus, signals applied to the B input connector will not be displayed.

In the Vc-B position of the DISPLAY switch, the comparison voltage is applied to the amplifier input where the A input signal is normally applied during differential mode of operation. The AC-DC-GND switch and input connector for the A input are not used.

NOTE

If a high-amplitude signal is applied to the unused connector, the AC-DC-GND switch for that connector should be set to GND to prevent possible crosstalk.

The dc comparison voltage is set by two controls: the Vc RANGE switch and the COMPARISON VOLTAGE control. The Vc RANGE switch has 4 ranges: 0 to -11, 0 to -1.1, 0 to +1.1, and 0 to +11 volts. The COMPARISON VOLTAGE control varies the comparison voltage over the range selected by the Vc RANGE switch and indicates the precise comparison voltage at a particular setting. The comparison voltage as read from the COMPARISON VOLTAGE control dial is independent of the MILLIVOLTS/CM or VARIABLE controls.

NOTE

The comparison voltage supply circuit in the W Unit maintains constant, accurate, comparison voltage as long as the -150- and +225-volt power supplies are in regulation and within their output voltage tolerance ratings. Be sure these and other regulated power supplies in the oscilloscope are operating properly.

Differential comparator mode of operation may be used to make the following voltage measurements: (1) measuring dc voltages, (2) measuring small ac or dc signals superimposed on dc, (3) measuring small ac signal variations on large ac, and (4) measuring high-amplitude low-frequency ac signals.

(1) Measuring DC Voltages

When the W Unit is used to make dc voltage measurements, the following general procedure (using input A as an example) can be used:

- a. Check that the DC BAL adjustment has been set properly.
- b. Place input A AC-DC-GND switch to GND, the DISPLAY switch to A-Vc and the MILLIVOLTS/CM switch to 50.
- c. Set the INPUT ATTN switch to a position that will attenuate the applied dc to a voltage of about 10 volts or less.
- d. Set the Vc RANGE switch to 0.
- e. Establish a reference line on the crt. This line will usually be the horizontal centerline of the graticule. Use the POSITION control to set the trace to the reference line. Once

the trace is set, do not move the POSITION control until the measurement has been made or a recheck is necessary.

NOTE

For greatest accuracy in establishing a reference, set the input A AC-DC-GND switch to DC and touch the probe tip to ground on the device under test. Then position the trace to the reference line.

- f. Set input A AC-DC-GND switch to DC.
- g. Connect input A probe to the dc voltage to be measured.
- h. Set the Vc RANGE switch to a voltage sufficient to offset the attenuated dc voltage of step c. The offsetting comparison voltage should be of the same polarity as the applied dc voltage.
- i. Set the COMPARISON VOLTAGE control to bring the trace onto the crt. Set the trace exactly on the reference line with the COMPARISON VOLTAGE control.
- j. Recheck the reference by setting the A AC-DC-GND switch to GND (or ground the probe tip) and the Vc RANGE switch to 0. If the trace does not coincide with the reference established in step e, reposition the trace to the reference with the POSITION control. Return the switches to their former positions.

NOTE

When making large dc measurements, allow a few moments for the trace to return to its original position.

k. Now the voltage can be determined by using the following formula:

$$\begin{matrix} \text{True} \\ \text{Comparison} \\ \text{Voltage} \\ \text{in Volts} \end{matrix} = \begin{matrix} \text{COMPARISON} \\ \text{VOLTAGE} \\ \text{Control} \\ \text{Reading} \\ \text{in Volts} \end{matrix} \times \begin{matrix} \text{INPUT} \\ \text{ATTEN} \\ \text{Switch} \\ \text{Position} \end{matrix} \times \begin{matrix} \text{Probe} \\ \text{Attenuation} \\ \text{Factor} \end{matrix}$$

The applied dc voltage is equal to the true comparison voltage. For example, supposing a +300-volt power supply is being measured and a 10X attenuator probe is used to connect to the power supply. Finally, assume the INPUT ATTN switch has been set to 10, the Vc RANGE switch to +11 and the COMPARISON VOLTAGE control to 2-9-85 (+2.985 volts). Substituting these values in the formula, the result is:

$$\text{True Comparison Voltage} = (+2.985) (10) (10)$$

$$\text{True Comparison Voltage} = +298.5 \text{ volts}$$

Thus, the +300-volt supply is actually +298.5 volts.

NOTE

To increase the resolution when matching the reference line and trace as in step i, set the MILLIVOLTS/CM switch to a higher sensitivity (lower deflection factor). Reestablish the reference and repeat the measurement as described in steps j and k. The formula given in step k applies regardless of the MILLIVOLTS/CM switch position.

Operating Instructions—Type W

(2) Measuring Small AC or DC Signals Superimposed on DC

Small ac or dc signals superimposed on a dc component can be measured accurately by first using the comparison voltage to effectively eliminate the dc component. The general procedure, using input A as the example, is as follows:

- Set the input A AC-DC-GND switch to DC, the DISPLAY switch to A-Vc and the POSITION control to midrange.
- Set the INPUT ATTEN switch so the combined signal to be applied to input A is attenuated to about 10 volts or less.
- Set the MILLIVOLTS/CM switch so the small ac or dc signal is not expected to overscan the screen.
- Apply the signal to input A.
- Set the Vc RANGE switch to a voltage sufficient to offset the attenuated signal of step b. Use the same polarity comparison voltage as the dc component signal to be offset.
- Set the COMPARISON VOLTAGE control so the small ac or dc signal is positioned onto the screen.
- If the small signal waveform overscans the screen or is too low in amplitude, reset the MILLIVOLTS/CM switch so the waveform is of suitable size.
- Measure the small ac or dc signal in the same manner as is done in conventional preamplifier operation using the ordinary formula:

$$\text{P-P Signal in Millivolts} = \frac{\text{Vertical Deflection in cm} \times \text{MILLIVOLTS/CM Switch Position} \times \text{INPUT ATTEN Switch Position}}{\text{Probe Attenuation Factor}}$$

or measure the signal by using the COMPARISON VOLTAGE control. First, use the COMPARISON VOLTAGE control to measure the difference between the lowest and highest points on the small ac or dc signal. Substitute this information in the following formula:

$$\text{P-P Signal in Volts} = \frac{\text{COMPARISON VOLTAGE Control Difference Measurement in Volts} \times \text{INPUT ATTEN Switch Position}}{\text{Probe Attenuation Factor}}$$

(3) Measuring Small AC Signal Variations on Large AC

The technique for measuring small ac-signal component variations on a large ac signal is essentially the same as that described for measuring small ac or dc signals superimposed on dc. The only difference is that the AC-DC-GND switch can be set to AC to block any dc component (if desired). The comparison voltage is then used to position the small ac signal component into view so the measurement can be made.

(4) Measuring High-Amplitude Low-Frequency AC Signals

High-amplitude low-frequency (below 20 kc) ac signals, up to 500 volts peak-to-peak applied to the W Unit input connector, can be measured using the slide-back technique. This

type of measurement is very similar to dc measurements except that it is **not** necessary to establish a zero voltage reference line.

- Before applying the signal to the W Unit, set the INPUT ATTEN switch to a setting that will reduce the expected amplitude of the signal to about 10 volts or less peak-to-peak amplitude.
- Set the A input AC-DC-GND switch to AC.
- Set the DISPLAY switch to A-Vc and the MILLIVOLTS/CM switch to 50.
- Apply the signal to the A input connector.
- Set the Vc RANGE switch to a range sufficient to offset the attenuated signal.
- Use the COMPARISON VOLTAGE control to bring the desired point on the waveform to graticule center. Note the dial reading.
- Set the Vc RANGE switch to a range in opposite polarity to that used in step (4)e.
- Use the COMPARISON VOLTAGE control to bring the other desired point on the waveform to graticule center. Note the dial reading.
- Find the difference voltage between the two dial readings obtained in step (4)f and (4)h. Then substitute this information in this formula:

$$\text{P-P Signal in Volts} = \frac{\text{COMPARISON VOLTAGE Control Difference Measurement in Volts} \times \text{INPUT ATTEN Switch Position}}{\text{Probe Attenuation Factor}}$$

AC-DC-Voltage Measurements Exceeding 500 Volts

Tables 2-2 and 2-3 list the maximum signal handling capabilities of the W Unit. If ac, dc or both ac and peak ac voltage components are greater than 500 volts maximum, use an attenuation probe to apply such voltages to the unit. The formula previously given already includes the probe attenuation as one of the factors to consider when obtaining a measurement. When the probe is used, do not exceed the maximum input voltage rating of the probe.

For example, if a P6023 Probe is used, the maximum rating of the probe is 1000 volts. If a 750-volt signal is applied to the probe tip, then the INPUT ATTEN switch should be set to 10 to attenuate the signal still further so the W-Unit amplifier is not overdriven. The probe attenuation and INPUT ATTEN switch reduces the signal to 7.5 volts which is well within the W-Unit amplifier rating and comparison voltage slide-back capabilities.

Vc OUTPUT Connector

The Vc OUTPUT connector mounted on the front panel of the W Unit permits monitoring the comparison voltage. The voltage at the connector is the same as that set up by the Vc RANGE and COMPARISON VOLTAGE controls, provided meter loading is no greater than one or two microamperes. Any infinite impedance voltmeter such as a digital voltmeter or any nulling type meter which draws negligible current can be used for monitoring purposes.

If the connector is loaded more heavily by an external meter, the comparison voltage available at the connector and applied to the input grid of the W Unit amplifier will not be the same as indicated by the COMPARISON VOLTAGE control. However, the voltmeter which is connected to the Vc OUTPUT connector will indicate the actual slide-back voltage. Therefore, it is possible to load the circuit considerably and still use the comparison voltage with considerable accuracy as long as the COMPARISON VOLTAGE dial reading is ignored and the reading of the voltmeter is used.

NOTE

Accidental grounding of the Vc OUTPUT connector will not damage the internal circuitry.

R \approx ∞ Position of the INPUT ATTEN Switch

When the INPUT ATTEN switch is set to R \approx ∞ position, the input connector is connected directly to the grid of the first stage and the grid-to-ground circuit is opened. For low-frequency measurements the input impedance is very high. The high input impedance is useful for measuring voltages in high-impedance circuits where minimum loading is desired and the voltage to be measured is within the ± 11 volt range of the W unit; for example, measuring grid-to-cathode bias. Differential comparator operation is used to make the measurement. At null, the comparison voltage is equal to the voltage being measured.

IMPORTANT

When using the R \approx ∞ position, be sure to set the AC-DC-GND switch to DC for the input to be used. Dc coupling permits the grid to be returned to ground through the device under test.

If the external device does not provide a dc return path for the grid, an external resistance (adequately shielded) must be connected between the input connector and ground. A practical resistor value to use for this purpose is 1000 megohms. If this value is used, the input resistance of the W Unit will be approximately 1000 megohms.

Grid current through a 1000-megohm resistor is typically on the order of 100 picoamperes but never exceeds 2 nanoamperes. This low current can be easily offset by using the comparison voltage.

For example, if the A input is used, connect the 1000-megohm resistor between the A input connector and the Vc OUTPUT connector. Set input A AC-DC-GND switch to DC and input B AC-DC-GND switch to GND. Set the DISPLAY switch to A-B and the Vc RANGE switch to -1.1 . Then, set the COMPARISON VOLTAGE control so the trace returns to a graticule line which will be used as a reference.

For instance, a current of 100 picoamperes through a 1000-megohm resistor is equal to 100 mv or 20 cm of deflection at 5 mv/cm. This amount of deflection is offset by -0.1 -volt comparison voltage so the W Unit can be used as a current meter for making 5 picoamp/cm measurements. Dynamic measurements of extremely high values of leakage resistance not ordinarily possible with the usual 1- or 10-meg input resistor can be made. Transmission line leakage resistance, for example, can be measured by connecting a well-filtered voltage source between the ungrounded shield of the coax and ground. The center conductor of the coax is connected to the W-Unit input connector. As an example, assume $+50$ volts was applied to the shield and the trace moved two cm from the reference. This is equal to 10 picoamperes of current. Using Ohm's law the leakage resistance would be 5×10^{12} ohms.

NOTES

Lined writing area with 25 horizontal lines.

SECTION 3

CIRCUIT DESCRIPTION

BLOCK DIAGRAM DESCRIPTION

This description is based on the block diagram located in Section 6 of this manual. Signals applied to the A and B input connectors pass through the INPUT ATTEN and DISPLAY switches to the grids of tubes V113 and V213 in the Input Cathode Follower stages. The INPUT ATTEN switches control the magnitude of the input signals applied to the stages, and the DISPLAY switch controls the mode of operation for the W Unit.

Accurate \pm dc comparison voltages are obtained from the Vc supply. These voltages can be applied to the grid of either V113 or V213 by means of the DISPLAY switch. In differential-comparator mode of operation the voltages are applied to one grid and the signal is applied to the other.

The low-capacitance, high-impedance input of the Input Cathode Follower stages isolate the input circuit from the succeeding stages. The Input Cathode Followers are designed to accept input signals as great as ± 15 volts without being overloaded. Special constant-current circuits tend to prevent the cathode followers from cutting off or drawing grid current with high-amplitude, low-frequency signals.

The output of the Input Cathode Followers is applied to the base circuits of the Differential Amplifier stage. This stage also employs a constant-current circuit to permit handling large common-mode signals without distortion. Gain of the stage and hence the vertical deflection factor can be controlled by means of the MILLIVOLTS/CM switch.

In differential-comparator mode of operation the voltages add differentially to the signal within the Differential Amplifier stage. When the W Unit is used for differential-input-preamplifier mode of operation, a similar operation occurs because the signals applied to both inputs add differentially in this stage. The resultant output is applied to the Output Amplifier stage. Here the signals are further amplified and then applied to the input of the oscilloscope vertical amplifier through pins 1 and 3 of the interconnecting plug. Overall gain of the W Unit at a maximum sensitivity of 1 mv/cm is 100, push-pull.

Throughout the following discussion refer to both the block and circuit diagrams in Section 6.

DETAILED CIRCUIT DESCRIPTION

Comparison Voltage Supply

To make the W Unit operate at its specified comparison voltage accuracy, the comparison voltage (Vc) supply must maintain a constant voltage independent of environmental temperature changes and differences in the regulated power supply voltages between one oscilloscope and another. To obtain this high accuracy the comparison voltage is derived from a precision diode reference element D301. This element is a special device which compensates itself for temperature. Its output is nominally 11.7 volts and the voltage remains constant within 0.001% per degree centigrade change.

When the Vc RANGE switch SW310 is set to the +11 or +1.1 position, D301 cathode is connected through R301 to the +225-volt supply to provide the plus (+) comparison voltage to the Vc output circuit. D301 anode is connected to ground. R301 sets the current for D301 so the element can operate in its temperature-stable region. The Vc output circuit, composed of the COMPARISON VOLTAGE control SW320 and R325 with associated components, make up the load for D301.

When the Vc RANGE switch is set to 0, D301 anode connects through R303 to the -150-volt supply and the Vc output circuit is disconnected. To take the place of the Vc output circuit, R306 is connected across D301 to simulate normal loading for the reference element. D301 cathode connects to ground.

When the Vc RANGE switch is set to -11 or -1.1, D301 anode connects through R303 to the -150-volt supply and the cathode is connected to ground. D301 anode also connects to the Vc output circuit to provide the minus (-) comparison voltages.

Comparison Voltage Range

The comparison voltage range circuitry consists of R308, R310, R313, and R315 connected to the associated switch positions of the Vc RANGE switch. The Vc RANGE switch selects the range; the COMPARISON VOLTAGE control in the Vc output circuit selects the digits within that range.

Resistor R308 is selected for value when paired with D301. The reference element is a 5% diode and so a value for R308 is chosen that will set the comparison voltage well within the adjustment range of the Vc CAL control R310. The Vc CAL control is small in value to minimize effect of R310 temperature coefficient and to provide sufficient resolution so the comparison voltage can be set accurately. The control is adjusted so the comparison voltage is exactly +11 volts as measured between the Vc OUTPUT connector and ground. As a necessary condition prior to adjusting R310, the Vc RANGE switch is set to +11 and the COMPARISON VOLTAGE control to 11 (10-10-0). This condition essentially places the Vc OUTPUT connector at the same voltage level as that obtained between the top end of R330 (referring to the Switching Diagram) and ground.

When the Vc RANGE switch is set to +1.1 or -1.1, a precision divider network consisting of R313 and R315 reduces the comparison voltage by 10:1 so the voltage is exactly 1.1 volt as measured between the Vc OUTPUT and ground with the COMPARISON VOLTAGE control set to 10-10-0 which, in this case, is 1.10.

When the Vc RANGE switch is set to the 0 position, no comparison voltage is applied to this portion of the circuitry or to the Vc output circuit.

The use of ± 11 - and ± 1.1 -volt ranges instead of the usual ± 10 - and ± 1 -volt ranges extends the comparison voltage ranges by 10%. This permits using the 10% increase range for overlapping coverages between ranges and to extend the highest ranges. For example, when using

Circuit Description—Type W

the 1.1-volt range, the COMPARISON VOLTAGE control can be used at the 1-volt level to make measurements without having to switch to the next higher range.

Comparison Voltage Output Circuit

The comparison voltage output circuit (see Fig. 3-1 and the Switching Diagram) is composed of the COMPARISON VOLTAGE control SW320 and R325 with associated circuitry. The COMPARISON VOLTAGE control is a combination of two controls: (1) switch SW320 selects the first digit within the range set by the Vc RANGE switch, and (2) the 10-turn potentiometer R325 selects the remaining digits.

Twelve resistors, R330 to R341, make up the main divider in the Vc output circuit. The comparison voltage is applied to the top end of the divider and the bottom end is grounded. A shunt divider consisting of R322, R323, and R325 is connected across two of the resistors in the main divider by means of SW320. The equivalent resistance of the shunted portion of the main divider is equal to 1 k. The TRACKING control R323 provides the means for setting this resistance accurately. Thus, the main divider is actually divided into eleven equal divisions of 1 k each. If the Vc RANGE switch is set to +11 or -11, for example, there will be one-volt drop across each 1 k resistor.

Switch SW320 has 11 positions to permit switching the shunt divider across two resistors at a time along the string of resistors in the main divider. Each position corresponds

to one digit of voltage. Variable control R325 in the shunt circuit is the vernier control for dividing the comparison voltage further so the smaller divisions of the voltage can be measured. For example, if the Vc RANGE switch is set to +11, SW320 is set to 6 and R325 is set to 125, the comparison voltage reading is +6.125 volts.

The comparison voltage set by R325 is applied through the DISPLAY switch directly to the comparator. In contrast, any signals applied to the A or B input connectors, depending on which input is selected, must pass through the INPUT ATTEN switch. The switch, by means of selectable attenuators, attenuates the signal 1, 10, 100 or 1000 times.

Besides being applied through the DISPLAY switch to the comparator, the same comparison voltage from R325 is also applied to the front-panel Vc OUTPUT connector. This connector permits connecting any nulling-type meter or infinite-impedance-type meter to this point so the voltage can be monitored. The output voltage at the connector is very limited in current output; therefore, meters which draw negligible current should be used to prevent measurement errors. For further information refer to the topic "Vc OUTPUT connector" in the Operating Instructions section of this manual.

Signals applied to input connectors A and B of the W Unit must pass through the AC-DC-GND switches to the INPUT ATTEN switches. Since the input circuits of the unit are the same and the amplifier is push-pull, the signal path for input A is described in some detail in this circuit description.

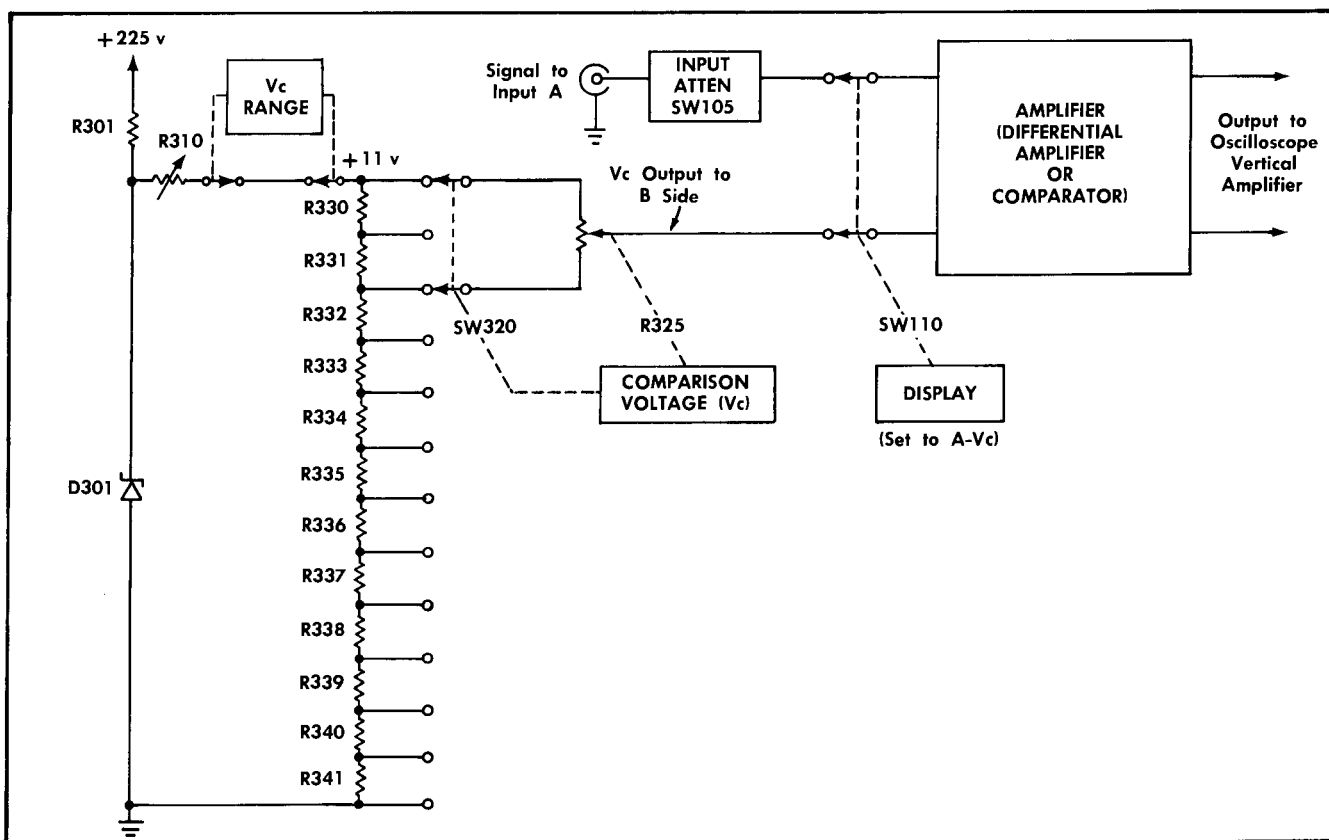

Fig. 3-1. Simplified diagram of the comparison voltage circuit and how it is connected to the amplifier for A-Vc differential-comparator mode of operation.

When the AC-DC-GND switch SW101 is set to AC, the signal is coupled through C102 to INPUT ATTEN switch SW105. When SW101 is set to DC, input coupling capacitor C102 is bypassed and the signal is applied directly to SW105. When SW101 is set to GND, the A input signal is disconnected and the input path to the INPUT ATTEN switch is grounded to prevent stray signal pickup and to permit operating the W Unit as a conventional preamplifier.

Input Attenuation

The INPUT ATTEN switch SW105/SW205 is a dual, gear driven, single-drive, five-position switch that selects the various attenuator sections for both inputs simultaneously. When the INPUT ATTEN switch is set to $R \approx \infty$, no attenuation takes place and there is no grid-to-ground resistance. Instead, the resistance path is through the external load to ground, provided the AC-DC-GND switch for the input connector to be used is set to DC.

When the INPUT ATTEN switch is set to 1, there is no attenuation of the signal. The grid-to-ground resistance is R105A and R105B connected in series. Resistor R105B is adjusted so the input resistance matches the 10X input resistance.

For the 10, 100, and 1000 settings of the INPUT ATTEN switch, attenuator networks are individually switched into the circuit to attenuate the signal before it is applied to the Input Cathode Follower stage. The attenuator networks are frequency-compensated rc voltage dividers. At dc and very low frequencies the dividers are resistive because the impedance of the capacitors is high and their effect in the circuit is negligible. As the frequency of the input signal increases, however, the impedance of the capacitors decreases and their effect in the circuit becomes more pronounced.

When the INPUT ATTEN switch is set to 10, for example, R106E adjusts the dc attenuator ratio so it is exactly 10 to 1. For higher frequencies, C106C, a coarse adjustment, and C106E, a fine adjustment, are used to frequency-compensate the divider so the capacitive reactance ratio is equal to the resistance ratio. The adjustments in the B input 10X attenuator are adjusted the same as the A input adjustments. When the input attenuator adjustments are accurately set, optimum common-mode rejection is achieved.

C106B in the 10X attenuator is adjusted so the input rc of the attenuator is $20 \text{ pf} \times 1 \text{ meg}$. When making the adjustment, an Input Time-Constant Standardizer is used as the reference. Each attenuator is "standardized" in this manner. Thus, an attenuator probe, when connected to the input connector and properly adjusted, will work into the same input time constant regardless of the INPUT ATTEN switch position with the exception of the $R \approx \infty$ position.

DISPLAY Switch

The DISPLAY switch SW110 connects one or the other input, or both in the A-B position, to the Input Cathode Follower stages. In the A-Vc position the A input signal is applied to the grid of V113 and the comparison voltage is applied to the grid of V213. A normal or upright display will be obtained. That is, a + voltage applied to input A moves the trace upward on the crt. A + com-

parison voltage, added differentially by the W Unit amplifier stages, drives the trace downward for obtaining a null.

In the Vc-B position, the B input signal is applied to the grid of V213 and the comparison voltage is applied to the grid of V113. The display will be inverted; that is, if a + voltage is applied to the B input, the trace moves downward. A + comparison voltage applied to the A input moves the trace upward to obtain a null.

In the A-B position, the W Unit is an ordinary differential amplifier. Both inputs are active and the difference between the A and B signals is displayed. In this mode of operation the comparison voltage is not used but it is available at the Vc OUTPUT connector.

Input Cathode Follower Stages

Signals from the display switch are applied to the Input Cathode Follower stages. The stage for the A input side consists of V124A, V113, V114A, and associated circuitry. For the B side, the stage consists of V124B, V213, V214A, and associated circuitry.

The wide dynamic operating range of the W Unit requires constant-current operation of the Input Cathode Follower stages and the Differential Amplifier stage that follows. To achieve this type of operation V113 cathode connects through V124A, R126, and R127 to -150 volts. Thus, 15-volt signal swings applied to the grid of V113 cause only a 0.5-volt change at the cathode of V124A, which produces considerably less current change than if the cathode of V113 were connected through a resistor to -150 volts. In addition, the plate of V113 is bootstrapped by cathode follower V114A. The bootstrapping action is through a compensated divider from the cathode of V113 to $+225$ volts. The divider consists of R118 and R119 compensated by C116 and C117. Bootstrapping minimizes V113 changes in characteristics by keeping the plate-to-cathode voltage change as small as possible with large signal swings.

Diode D113 protects V113 against extreme turn-on conditions such as those encountered when plugging the W Unit in a turned-on oscilloscope. In such a condition the diode conducts and limits the grid-to-cathode positive-bias voltage to about 0.6 volt until V113 starts conducting normally.

The DIFF BAL control R223, in conjunction with R122 and R222 serve to load the cathodes of the bootstrapping cathode followers V114A and V214A so both sides can be gain-balanced. By adjusting R223 the gain of V114A, for instance, can be made to decrease while the gain of V214A increases. This will differentially adjust the gain of V114A and V214A to make up for small differences in the characteristics of V113 and V213. The gains of V113 and V213 must be the same to obtain optimum common-mode rejection.

To prevent trace shift when changing MILLIVOLTS/CM switch SW150 position or rotating the VARIABLE control R155 after the unit has warmed up, the emitter potentials of Q154 must be equal and the plate potentials of V114B and V214B have to be the same. This is accomplished by adjusting the DC BAL control R127. Adjustment of R127 varies the cathode voltage of V113 and V213 (through V124A and V124B) in opposite directions to compensate for slight dc differences between the two sides.

Circuit Description—Type W

Differential Amplifier

Signals at the cathodes of V113 and V213 are applied through D142A and D142B to the bases of Q154A and Q154B in their respective channels of the Differential Amplifier stage. This stage consists of V114B, Q154A, Q134, Q154B, and V214B with associated circuitry. The tube-and-transistor combination forms a hybrid circuit which has a very high output impedance and gain of slightly over 10 at a sensitivity of 1 mv/cm. This circuit is capable of handling a large common-mode signal and differentially suppressing this signal so that it will not be applied to the bases of transistors Q174 and Q274 of the following stage. The high output impedance aids in minimizing any current change in the circuit due to the common-mode signal.

Transistors Q154A and Q154B are the comparators in the circuit because they divide up the current passing through them. The current through each transistor is dependent on the relative difference voltages on each base. Q134 is the current source for the comparator transistors and for diodes D142A and D142B. The diodes serve to disconnect the Differential Amplifier stage from the Input Cathode Followers whenever large signals overdrive the input stage. For example, if B input is grounded and a large negative-going signal overdrives the A Input Cathode Follower stage, D142A will reverse bias to disconnect the Differential Amplifier from the preceding stage. If a large positive-going signal overdrives the A input side, the opposite occurs. That is, diode D142B reverse biases and disconnects the Differential Amplifier stage from the B Input Cathode Follower stage. The result is the same as applying a large negative-going signal to the B input side.

The gain of the stage is set by rotating the VARIABLE control R155 to its lowest resistance or CALIB setting and by adjusting the GAIN control R157 to get the correct amplitude display on the crt. When the VARIABLE control is turned fully counterclockwise away from its CALIB position, the gain is decreased by a factor of at least 2.5. However, this ratio is actually greater than 2.5 to 1 due to SW155. When the control is turned a few degrees counterclockwise from the CALIB position, SW155 closes and shorts out R157. Gain increases somewhat, thus providing overlapping coverage between the calibrated MILLIVOLTS/CM switch settings.

Resistor R152, connected from the emitter of Q154A to the grid of V114B, bootstraps V114B. The cathode bias for V114B is the emitter-to-collector bias of Q154A. If the emitter rises, the grid rises. This is a similar circuit to the one used in the Input Cathode Follower stage. In the 1 mv/cm position of SW150 the load resistor for one side is R149 and for the other side it is R249. This makes the load equal to 3 k differentially. To decrease the gain in a 1-2-5 sequence, R165 through R169 are used as shunt resistors. Thus, the sensitivity of the W Unit can be changed from 1 mv/cm to 50 mv/cm. In differential-comparator mode of operation this 50-to-1 gain range is useful as a vertical magnifier for the signal. The vertical size of the waveform changes but not the comparison voltage.

T150 is a ferrite bead that acts as a suppressor for high-frequency oscillations. Using the bead is similar to adding a resistor in the circuit to lower the Q of the inductance.

Output Amplifier Stage

The Output Amplifier stage consists of Q174, Q274, Q184, and Q284 with associated circuitry. This circuit is

connected in a feed-back arrangement to provide an overall gain of about 10. The output impedance of this stage is low to drive the connector impedance. Components R184, R284, C184, and C284 are used to compensate the transient response.

Feedback is provided through R174 and C174 on one side; for the other side the feedback path is through R274 and C274. The DC LEVEL control R280 establishes the collector voltages of Q184 and Q284 through Q174 and Q274. To adjust the control, the plates of V114B and V214B are tied together and the DC LEVEL control is adjusted to obtain a 6-volt emitter-to-collector drop across Q184 or Q284.

Normal vertical positioning of the trace is accomplished by rotating the POSITION control R279. The positioning range of this control is about ± 7.5 cm. As the control is rotated in either direction from its midrange position, it shunts more current to one transistor or the other. The paths for the positioning currents are through R178 and R278 to the emitters of Q174 and Q274.

To give the POSITION control equal range above and below graticule center, POSITION RANGE control R176 is provided. This control is adjusted by first setting the POSITION control to midrange and connecting the plates of V114B and V214B together. Then, R176 is adjusted so the trace coincides with graticule center.

Power Supply Decoupling

The +225-, +100-, and -150-volt supplies are decoupled to prevent any oscilloscope power-supply signals from affecting the operation of the W Unit. Capacitor C286 provides a bypass path to ground for any signal variations that might come in from the +75-volt source.

Heater Circuit

Direct current is used to operate the heaters in the W Unit. A constant dc voltage source instead of ac is used to avoid the possibility of cathode modulation at line frequency.

A total current of 182 ma is required for proper heater operation. A current of 150 ma is available through pin 15 of the interconnecting plug and the balance (32 ma) is obtained from pin 10 (+100-volt supply) through the network consisting of R286, R288, and D288.

The voltage at pin 15 is +75 volts. This voltage is obtained from the +100-volt regulated supply by dropping 25 volts either across two tubes or a resistor in the oscilloscope, depending on whether the oscilloscope has two time bases or one. Since the heater string requires only 48 volts for proper operation, about 27 volts is dropped across resistor R290.

Tubes V113 and V213 draw about 132 ma; therefore 50 ma is shunted through R292, R293, and R295. One of the resistors, R293, is the HEATER BAL control. This control enables the cathode temperature of V113 and V213 to be

differentially adjusted. As a result, tubes that vary considerably in characteristics can be made to operate at about the same bias. Lastly, the control enables the DC BAL control R127 to have sufficient range. Thus, the HEATER BAL control acts as a coarse dc balance adjustment, and the DC BAL control serves as a fine adjustment.

At the junction of D288 and R288, +81 volts is taken off for application to the plate circuit of V114B and V214B. The +81 volts establishes the dc output level for the W Unit amplifier.

24-Volt Power Source

The +24-volt power is obtained from Zener D193. The cathode end of D193 connects through R193 to the +100-volt supply and the anode terminal connects to ground.

The +24 volts is applied to the center arm of the DIFF BAL control R223. Elevating the control to this voltage level reduces the loading effect on V114A and V214A by reducing the standing current. Since the arm of R223 usually ends up being near center when properly adjusted, current drawn through R122 and R222 is very small.

SECTION 4

MAINTENANCE

PREVENTIVE MAINTENANCE

Cleaning the Interior

To clean the interior of the W Unit, blow off the accumulated dust using low-velocity compressed air. A very high-velocity air stream should be avoided, however, to prevent damage to some of the components.

Visual Inspection

Many potential or existing troubles can be detected by a visual inspection of the unit. For this reason, a complete visual check should be performed periodically or every time the unit is inoperative, needs repair, or needs to be calibrated. Visual defects may include loose or broken connections, damaged connectors, improperly seated tubes or semiconductors, and scorched or burned parts.

The remedy for these troubles is readily apparent except in the case of heat-damaged parts. Damage to parts due to heat is often the result of other less apparent troubles in the unit. It is essential that the cause of overheating be determined and corrected before replacing the damaged parts.

Checking Tubes and Semiconductors

Periodic checks on the tubes and semiconductors using a tester are not recommended. Tube and semiconductor testers in many cases indicate a defect when a component is operating satisfactorily in a circuit, and fail to indicate defects which affect circuit performance.

The true test of tube or semiconductor usability is whether or not the component works properly in the circuit. If it is working correctly, it should not be replaced.

Calibration

The W Unit should provide many hours of trouble-free operation. However, to insure the reliability of measurements, check the calibration of the unit after each 500-hour period of operation (or every six months if the unit is used intermittently). A complete step-by-step procedure for calibrating the unit and checking its operation is given in the Calibration section of this manual.

CORRECTIVE MAINTENANCE

Soldering Precautions

In the production of Tektronix instruments, a special silver-bearing solder is used to establish a bond to the ceramic terminal strips. This bond can be broken by repeated use of ordinary tin-lead solder, or by excessive heating of the junction with a soldering iron. Occasional use of ordinary tin-lead solder will not break the bond if normal heat is applied.

If you frequently perform work on Tektronix instruments it is advisable to have a stock of solder containing about 3% silver. This type solder is used often in printed circuitry and is generally available locally. It may also be purchased directly from Tektronix in one-pound rolls. To order the solder specify part number 251-514.

Because of the shape of the terminals on the ceramic terminal strips, you may prefer to use a wedge-shaped tip on your soldering iron. Such a tip allows you to apply heat directly to the junction and reduces the overall heating effect. It is important to use as little heat as possible while producing a full-flow joint.

When removing or replacing components mounted on the ceramic strips, the procedure can be summed up as follows:

1. Use a soldering iron having a rating of about 40 to 60 watts.
2. Apply one corner of the soldering iron tip to the notch where you intend to unsolder the lead.

NOTE

If the tip of the iron is placed partly in the notch, do not twist the iron as this might chip or break the ceramic strip.

3. Apply only enough heat to melt the solder and remove the lead. If long-nose pliers are used to grip the lead to be removed, use the very tip of the pliers to keep from drawing away too much heat.
4. When resoldering the lead, apply enough heat to make the solder flow freely.

5. Do not attempt to fill the notch on the strip with solder; instead, apply sufficient solder to cover the wire adequately and to form a slight fillet on the wire.

In soldering leads to metal terminals (examples: interconnecting plug, tubes or transistor socket) a similar technique should be employed. Use a soldering iron tip having a shank diameter of $\frac{1}{8}$ " so that it will go through small spaces between wiring. Allow the joint to heat sufficiently to permit the solder to flow freely and to form a smooth, slight fillet around the wire. Due to the high-frequency requirements of the W Unit, many components are soldered in place with very short leads; for example, in the input circuits of the amplifier. When these components are replaced, the leads should be clipped to match the leads of the components that were removed. After clipping wires, be sure to remove all clippings that fall into the unit.

In soldering leads or coax braids to ground use a 50-60-watt iron with a tip having a shank diameter of about $\frac{1}{4}$ ". The higher wattage iron and heavier tip will assure that the joint receives adequate heat to make a good solder joint.

Removing Ceramic Terminal Strips

To remove a ceramic terminal strip, unsolder all components and connections, then pry the strip with nylon studs attached out of the chassis. Another method is to use diagonal cutters to cut off one side of each stud to free the strip, but try not to damage the nylon spacer. After removing the strip, the remainder of each stud can be easily extracted from the chassis with a pair of pliers. The studs need not be salvaged since new ones are furnished with the new strips. If the spacers are not damaged, they may be reused as long as they hold the strip assembly securely.

To install a new strip, place the spacers in the chassis holes, insert the stud through the spacers, and press down on top of the strip above the studs. Use a plastic or hard rubber mallet, if necessary, to seat the studs firmly. Be sure to tap lightly **directly above** the studs and drive them down in equal increments to keep from placing too great a strain on the strip. Fig. 4-1 illustrates the way the parts fit together. If desired, the extending portion of the stud pins can be cut off to within about an eighth of an inch of the lower end of the spacers.

Observe all soldering precautions described earlier when soldering leads to the strip.

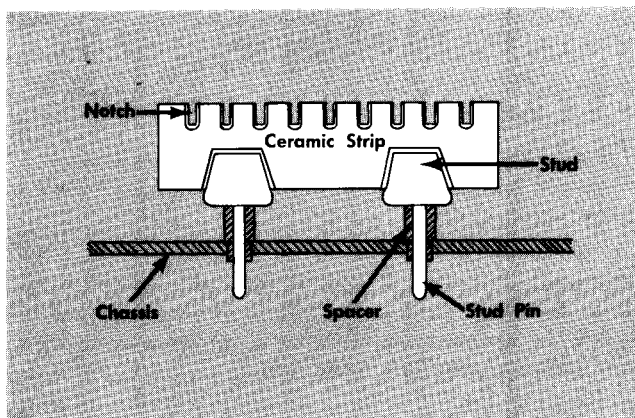

Fig. 4-1. Installation of a ceramic strip.

Removing and Replacing Switches

If either of the AC-DC-GND switches is defective, remove and replace the switch. Use normal care in disconnecting and reconnecting the leads. To remove the nut that mounts the switch to the panel, use a 1" open end wrench which is ground down for clearance.

Single wafers or mechanical parts on rotary switches are not normally replaced. If the switch is defective, the entire switch should be replaced. The INPUT ATTEN, DISPLAY, and the MILLIVOLTS/CM switches can be ordered through your Tektronix Field Engineering Office either unwired or wired, as desired. Refer to the Parts List to find the unwired and wired switch part numbers.

CAUTION

When disconnecting or connecting leads to a wafer-type switch, do not let solder flow around and beyond the rivet on the switch terminal. Ex-

cessive solder can destroy the spring tension of the contact.

OBTAINING REPLACEMENT PARTS

Standard Parts

Replacements for all parts used in constructing the W Unit can be purchased through your local Tektronix Field Engineering Office. Many of the components, however, are standard electronic parts that can usually be purchased locally in less time than required to obtain them from Tektronix, Inc. Before purchasing a part, be sure to consult the Parts List of this manual to determine the tolerance and rating required. The Parts List gives the values, tolerances, rating, and Tektronix part number for all components used in the unit.

Special Parts

In addition to the standard electronic components mentioned in the previous paragraph, special parts are also used. These parts are manufactured or selected by Tektronix to satisfy particular requirements, or are manufactured especially for Tektronix by other companies. These parts and most mechanical parts should be ordered from Tektronix, since they are normally difficult or impossible to obtain from other sources. Order all parts through your local Tektronix Field Engineering Office.

TROUBLESHOOTING INFORMATION

Introduction

In the event a trouble develops, use the information in this portion of the manual to more efficiently troubleshoot the W Unit. The information starts with preliminary checks to make, and then advances to detailed circuit troubleshooting.

Front-Panel Controls

Before troubleshooting, double-check the front-panel controls for proper settings. Also, check the front-panel screwdriver adjustments to determine if their settings are proper. This is important since symptoms caused by incorrect front-panel control settings are not described in this section of the manual.

If you are in doubt as to the proper settings of the controls or their functions, refer to the Operating Instructions section. If the front-panel controls are properly set and you find that a trouble definitely exists, first check to determine whether the trouble is in the oscilloscope or the W Unit.

Type W or Oscilloscope

When following a troubleshooting procedure, it is assumed that the oscilloscope used with the W Unit is operating normally. Since this is not always the case, check the operation of the oscilloscope before attempting to troubleshoot the W Unit.

Troubles occurring in the oscilloscope can usually be detected by substituting another plug-in unit for the W Unit.

NOTE

Be sure the proper line voltage is applied to the oscilloscope used with the W Unit.

If the W Unit is definitely at fault and not the associated oscilloscope, make a careful operational check of the W Unit. Carefully note the effect that each front-panel control has on the symptom. By analyzing such effects, you can sometimes isolate a trouble to either a defective control or circuits containing the trouble. In addition, the normal or abnormal operation of each control should indicate checks to make.

The remainder of this section deals with more detailed troubleshooting. Table 4-1 gives the interconnecting plug-to-ground resistances. Table 4-2 gives many symptoms of troubles as an aid to isolating the trouble to certain stages or circuits.

A step-by-step method for checking and adjusting the W Unit is given in the Calibration section. The calibration procedure can be used to check the operational standards of the unit. Any deficiency that shows up while performing the steps can lead you to the area at fault and the possible causes.

Diagrams

Block and circuit diagrams are contained in the pullout pages in section 6. The circuit diagrams contain component circuit numbers, voltages, and waveforms. Conditions under which the voltages and waveforms were taken are also indicated adjacent to the diagrams.

Coding of Switch Wafers

Switch wafers shown on the circuit diagrams are coded to indicate the physical location of the wafer on the actual switches. The number portion of the code refers to the wafer number of the switch assembly. Wafers are numbered from the first wafer located behind the detent section of the switch to the last wafer. The letters F and R indicate whether the front or rear of the wafer is used to perform the particular switching function. For example, 2R of the MILLIVOLTS/CM switch is the second wafer when counting back from the detent section, and R is the rear side of the wafer.

Cable Color Coding

All wiring in the W Unit is color coded to facilitate circuit tracing. The power-supply wires originating at the W Unit interconnecting plug and the +24-volt source are identified by the following code; the widest stripe identifies the first color in the code.

Supply Voltage	Cable Color Code
+225 v	Red/red/dark-brown on white
+100 v	Dark-brown/black/dark-brown on white
+75 v	Green on white
+24 v	Red/black/brown on white
-150 v	Dark-brown/green/dark-brown on tan

Test Equipment

When preparing to circuit troubleshoot the W Unit, you may find useful some of the minimum equipment described here.

(1) Transistor Tester

Description: Tektronix Type 575 Transistor-Curve Tracer.

Purpose: Test transistors and diodes used in the W Unit.

(2) VOM

Description: 20,000 Ω /v dc. Be sure the test prods are well insulated (except for the very tip) to prevent accidental shorts when reaching a test point.

Purpose: Precision and general-purpose use. Can also be used to check transistors and diodes if used with care. When checking semiconductors use ohmmeter ranges (usually $R \times 1K$ and higher) that deliver less than 2 ma of current at full deflection. Preferably, use a good transistor and diode tester in place of the VOM.

(3) Test Oscilloscope

Description: Bandwidth, dc to 300 kc or better. Calibrated vertical deflection factors down to 5 mv/cm without a $10 \times$ probe (with a $10 \times$ probe, 50 mv/cm). Input resistance, 1 megohm without a $10 \times$ probe; 10 megohms with a $10 \times$ probe.

Purpose: For low-frequency signal-tracing and checking dc levels in the amplifier stages.

(4) Flexible Plug-In Extension

Description: 30" long, Tektronix Part No. 012-038.

Purpose: Permits operating the W Unit out of the oscilloscope plug-in compartment for better accessibility.

(5) BNC Coaxial Cables (two required)

Description: Equipped with BNC plug connectors on each end. Tektronix Part No. 012-057.

Purpose: Use in low-frequency signal-tracing setup to apply the oscilloscope calibrator signal to the W Unit and to the test oscilloscope Ext Trig input connector.

(6) BNC T Connector

Description: Fits one BNC jack and two BNC plugs. Tektronix Part No. 103-030.

Purpose: Use in a low-frequency signal-tracing setup for connecting to the two BNC coaxial cables (item 5) and to the Cal Out connector on the oscilloscope used in the W Unit.

(7) Miscellaneous: Replacement tubes, transistors, and diodes.

TABLE 4-1

Approximate Resistance Between the Interconnecting Plug Pins and Ground

Type of Meter: VOM ¹			Type of Meter: Manufactured By: Model No.: Type W Serial No.:	
Pin No.	Resistance Readings ²	Ohms Range Used	Resistance Readings ²	Ohms Range Used
1	9.4 k, 5.4 k	R×1K		
2	0 (Gnd)			
3	9.4 k, 5.4 k	R×1K		
4	Infinite (No connection)			
5				
6				
7				
8				
9	13.9 k	R×1K		
10	870 Ω	R×100		
11	10.7 k, 8.6 k	R×1K		
12	Infinite (No connection)			
13				
14				
15	190 Ω	R×100		
16	Infinite (No connection)			

¹ VOM used to obtain these measurements is a 20,000 Ω/v dc meter with a center-scale reading of 4.5 k on the RX1K range. Full scale current for the RX1K range is 320 μa.

² Ohmmeter leads are first connected one way and then the other to get the two readings.

Interconnecting-Plug Resistance Checks

Table 4-1 lists the approximate resistance measured between the interconnecting-plug pins and ground of the 16-pin plug located on the rear panel of the W Unit. These measurements were taken with the unit disconnected from the associated oscilloscope, and the Vc RANGE switch was set to +11 or -11. The measurements are particularly useful for locating a possible short circuit or low-resistance path in the unit, if such trouble should occur.

The resistance measurements vary considerably since semi-conductors are used in the circuitry. In addition, the readings can vary as much as 50% due to the type of ohmmeter in use, even when using the same ranges. Therefore, blank columns are provided in the table for logging your own measurements, and the type of meter used, for future reference.

Significant differences between ohmmeter types are: (1) the amount of internal voltage used, (2) the currents delivered for full-scale deflection in each range, and (3) the scale readings on the meter itself. If ohmmeters differed less in these respects, the resistance measurements given in the table would be more typical.

Troubleshooting Chart

The Troubleshooting Chart, Table 4-2 lists a variety of symptoms with possible causes and the probable area at fault. If there is an apparent trouble in your W Unit, find the symptom in the table that most nearly describes the trouble in your plug-in unit.

Then perform the checks described in the table. For further aid, the chart may direct you to either of two topics

TABLE 4-2
Troubleshooting Chart

Symptoms	Checks to Make	
	Possible Causes	Area at Fault
No trace.	Check these nominal supply voltages in the W Unit: +225 v, +100 v, +81 v, +75 v, +24 v, and -150 v. If any of these voltages are incorrect, find the trouble before going to the third column. Some possible causes are: Defective interconnecting plug. R190, R192, or R195 open. Open filament in one of the tubes.	Check for dc imbalance in the W Unit amplifier stages. Refer to topic — Isolating DC Imbalance.
Stationary trace. Cannot be positioned.	C184 or C284 shorted.	Check Output Amplifier Q174/Q274/Q184/Q284 stage.
Trace but no signal display when signal is applied to input A.	Defective AC-DC-GND switch SW101. Open connection at the A input connector or at SW101 switch.	Check input circuit of V113.
Trace but no signal display when signal is applied to input B.	Defective AC-DC-GND switch SW201. Open connection at the B input connector or at SW201 switch.	Check input circuit of V213.
Low Gain.		Signal trace through the W Unit. Refer to topic — Signal Tracing.
Comparison Voltage incorrect; RANGE switch set to -11, -1.1, +1.1, or +11.	D301 defective.	Check for trouble in these circuits: Vc Supply, Vc Range, or Vc Output.

that follow the chart. The topics are (1) Isolating DC Imbalance, and (2) Signal Tracing.

Isolating DC Imbalance

To make a free-running trace appear within the usable viewing area of the crt, the dc output voltage at pins 1 and 3 of the interconnecting plug must be essentially equal—that is, within a fraction of a volt (see Fig. 4-2). As little as 0.4-volt difference between these two points positions the beam above or below the range of visibility, assuming the W Unit is used with an oscilloscope having a 6-cm high viewing area.

The dc output voltages depend on the dc balance in all stages of the W Unit amplifier. Since the stages are dc coupled, a condition anywhere between the input and output that unbalances the output voltage more than 0.4 volt can cause the trace to deflect out of the viewing area.

The procedure for isolating the cause of dc imbalance is to set the W Unit front-panel controls as follows:

Vc RANGE	As is
COMPARISON VOLTAGE	As is
AC-DC-GND (both A and B)	GND
INPUT ATTEN	1
DISPLAY	A-B
MILLIVOLTS/CM	50
VARIABLE POSITION	CALIB
	Centered

Then, connect a dc voltmeter (starting from the input) between corresponding points in the amplifier as shown in Fig. 4-2 to determine where the imbalance originates. For example, if the voltmeter is connected between the cathodes of V113 and V213 and the reading is within the range indicated in the illustration, then this stage is properly dc balanced. It also means that the DIFF BAL, DC BAL, and HEATER BAL controls are properly set. If the voltmeter is connected between the plate of V114B and the plate of V214B and if the reading is greater than the voltage range given in the illustration, then the dc imbalance is originating in the Input Amplifier stage V114B/Q154A/Q134/Q154B/V214B. Make detailed voltage and resistance checks to determine the exact cause of the dc imbalance.

Signal Tracing

The following information supplements Table 4-2. A method is described here for checking waveform amplitude, polarity, and dc level at the points where the waveforms were obtained on the diagrams. The technique used here is limited to low frequency because a plug-in cable extension is used to operate the W Unit out of the oscilloscope plug-in compartment. Using the cable extension permits access to all sides of the W Unit for detailed signal tracing and troubleshooting.

After the W Unit is working properly at the low frequencies, then it is easy to go directly to the Calibration procedure to check square-wave response or differential rejection at the higher frequencies.

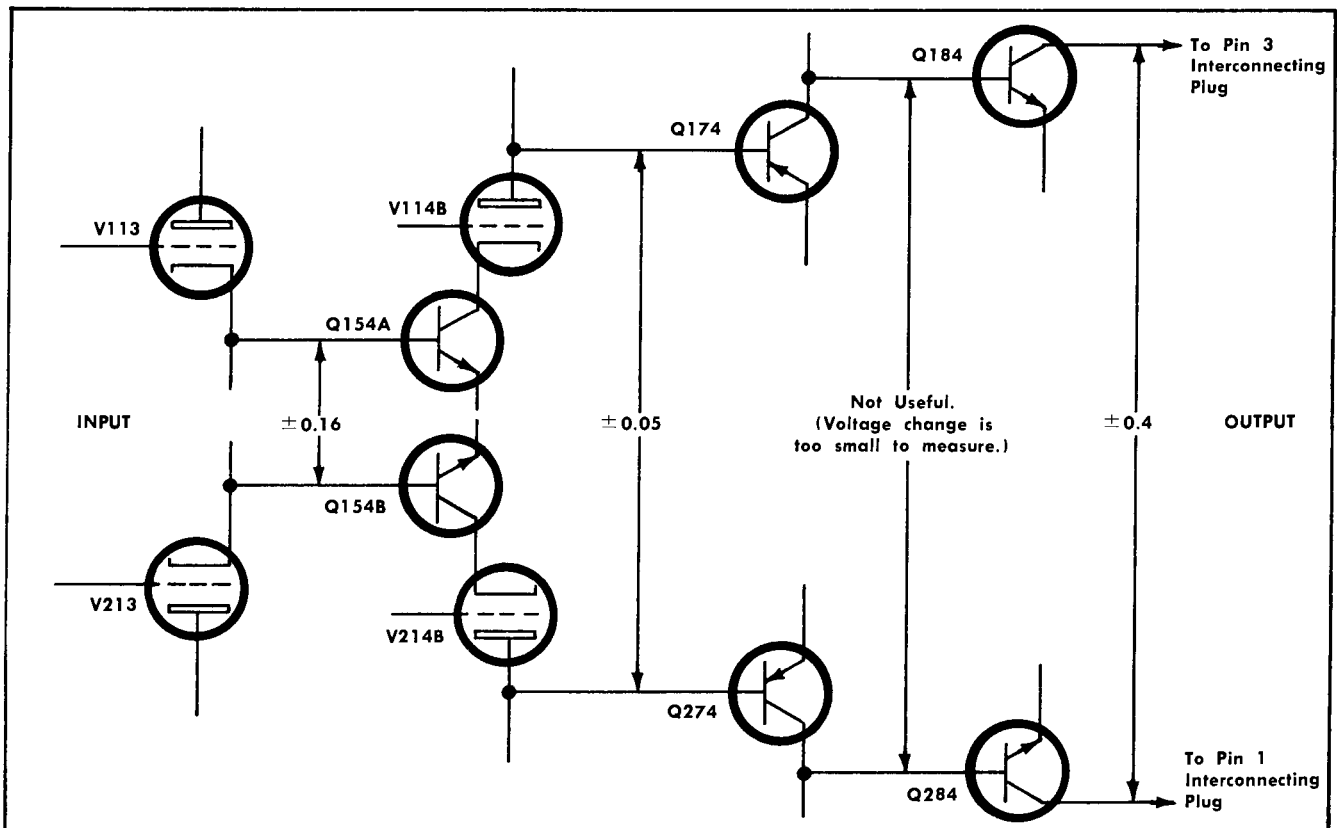

Fig. 4-2. Simplified schematic diagram of the W Unit amplifier stages.

IMPORTANT

The amplitude and dc level shown adjacent to each waveform on the schematics are intended as a guide and are not absolute. They may vary due to gain-adjustment setting, normal manufacturing tolerances, and characteristics of tubes and semi-conductors.

To signal trace the W Unit amplifier stages, proceed as follows:

1. Set the front-panel controls of the W Unit to the same positions as indicated in the important note adjacent to the High-Gain Differential Comparator schematic diagram.
2. Connect a 30" plug-in cable extension between the W Unit and the associated oscilloscope.
3. Apply a 2-volt peak-to-peak calibrator signal from the oscilloscope Cal Out connector through coax cables to the W Unit A input connector and to the test oscilloscope Ext Trig input connector.
4. Set the test oscilloscope input coupling switch to AC.
5. Touch the tip of the probe to the rear side of the A input connector. Set the front-panel controls on the test oscilloscope to display one or two cycles of the calibrator waveform. Be sure to set the test oscilloscope triggering controls for external triggering and display the first 1/2-cycle of the waveform as positive going. The displayed

waveform will then correspond to the input waveform polarity shown at the A input connector on the schematic diagram. Disconnect the probe.

6. Touch the probe tip to the desired test point in the W Unit circuitry. Set the test oscilloscope Volts/Cm switch to correspond to the setting given at the left of the waveform on the diagram.
7. Check amplitude and phase of the waveform. Then disconnect the probe.
8. Set the test oscilloscope input coupling switch to DC. Preset the test oscilloscope Volts/Cm switch such that the expected dc voltage to be measured in step 9 will keep the display within the graticule area. Ground the probe tip to the W Unit chassis and position the trace to establish a zero reference point.
9. Touch the probe tip to the same test point you used in step 6 of this procedure. Determine the dc level of the waveform by measuring the voltage between the reference point established in step 8 and the dc-level point indicated at the right side of the waveform shown on the schematic. Disconnect the probe.
10. Continue on to the next test point and repeat steps 6 through 9 until you reach a test point where an abnormal indication is obtained. Then proceed with detailed troubleshooting checks to find the cause of the trouble. Such checks usually consist of transistor or tube substitution, and voltage and resistance checks.

SECTION 5

CALIBRATION

Introduction

The W Unit should be calibrated after each 500 hours of operation, or at least every six months. Also, when transistors, tubes, and other components are changed, the calibration of the circuit under repair should be checked.

The instructions that follow are arranged in proper sequence for calibrating and checking the performance of the unit. The steps may be performed out of sequence, or a single step may be performed individually. However, it may be necessary to refer to the preceding step(s) and/or preliminary procedure for additional setup information.

NOTE

Steps whose titles begin with the word "Check" permit you to check the operational standards of the unit with very little change, if any, in the setup. All other steps are adjustment steps. Thus, if you choose not to do the checks, the adjustment steps can be found easily.

EQUIPMENT REQUIRED

The following equipment, or its equivalent, is required for a complete calibration of the W Unit.

(1) Type 530- or 540-series oscilloscope.

Requirements: Vertical amplifier gain, pass band and risetime must meet the specifications of the W unit.

NOTE

If a 530-series oscilloscope is used, omit step 19 in the calibration procedure since effect of the high-frequency adjustments will not be apparent.

(2) Amplitude calibrator (optional).

Description: Output frequency of about 1 kc; peak-to-peak output amplitudes of 5, 10, 20, 50, 100, and 200 mv; amplitude accuracy of 1% or better.

Purpose: For use in performing steps 11 and 12 of the calibration procedure if greater accuracy than that provided by the oscilloscope (item 1) calibrator is needed.

(3) Precision dc voltmeter. Nulling type with infinite impedance at null.

Required specifications: Accuracy of 0.05% or better; resolution of 50 μ v or better. If a John Fluke Differential Voltmeter is available, use Model 801B or equivalent. If an accuracy of $\pm 0.01\%$ is desired, use a Model 821A.

(4) DC voltmeter (VOM). Sensitivity of 20,000 Ω/v at full deflection.

(5) Audio sine-wave generator.

Required specifications: Output frequencies of 60 cps, 20 kc, and 500 kc at 20 volts peak-to-peak (10-volt peak referenced to ground).

(6) Sine-wave generator, Tektronix Type 190B Constant-Amplitude Signal Generator.

Required specifications: Output frequencies of 50 kc (reference) and a range of 8 to 23 mc; output amplitude must be adjustable (manually or automatically) for a constant amplitude at the stated frequencies; output amplitude range adjustable from 40 mv to 10 volts peak-to-peak.

(7) Square-wave generator, Tektronix Type 105.

Required specifications: 13-nsec or less risetime into a 50-ohm cable terminated at both ends; output frequencies of 1 and 10 kc; output amplitude variable from 10 to 100 volts across its internal 600-ohm load.

(8) Square-wave generator, Tektronix Type 107.

Required specifications: 3-nsec or less risetime into a terminated 50-ohm cable; output amplitude range of about 0.1 volt to 0.5 volt peak-to-peak; output frequency of about 450 kc.

(9) Input time constant standardizer.

Description: $RC = 1 \text{ meg} \times 20 \text{ pf}$, 2X voltage attenuation; equipped with one BNC plug and one BNC jack connector fittings; Tektronix Part No. 011-066.

(10) Two 50-ohm (nominal impedance) coaxial cables, 42" long, with a BNC connector on each end. Tektronix Part No. 012-057.

(11) 50-ohm (nominal impedance) coaxial jumper cable, 20" long; equipped with BNC connector on each end. Tektronix Part No. 012-076.

(12) 50-ohm 10:1 T attenuator, $\frac{1}{2}$ w, with BNC plug-and-jack connector fittings. Tektronix Part No. 011-059.

(13) 50-ohm 5:1 T attenuator, $\frac{1}{2}$ w, with BNC plug-and-jack connector fittings. Tektronix Part No. 011-060.

(14) 50-ohm termination, 1 w, with BNC plug-and-jack connector fittings. Tektronix Part No. 011-049.

(15) BNC T connector. Fits a BNC jack and accepts two BNC plugs. Tektronix Part No. 103-030.

(16) Two connector adapters. Single binding post fitted with a BNC-jack connector fitting. Binding post accepts a banana plug. Tektronix Part No. 103-033.

(17) BNC coupling adapter. BNC jack on each end. Fits BNC plugs. Tektronix Part No. 103-028.

(18) Patch cord, 6" long, with banana plug-and jack combination connector on each end. Tektronix Part No. 012-024.

Calibration—Type W

(19) Two patch cords, 18" to 24" long, with banana plug-and-jack combination connector on each end. Tektronix Part No. 012-031 (18" cord).

(20) Precision Dc Divider. 10:1 and 100:1 attenuation. Tektronix Part No. 067-503.

(21) Miscellaneous (one each).

Small screwdriver with a $\frac{1}{8}$ " wide tip to fit the small screwdriver-adjust potentiometers.

Screwdriver with a $\frac{3}{16}$ " wide tip to fit the larger screwdriver-adjust potentiometers.

Insulated low-capacitance screwdriver, Jaco No. 125, $1\frac{1}{2}$ " shank, $\frac{1}{8}$ " wide metal tip. Tektronix Part No. 003-000.

4" jumper lead with miniature insulated alligator clips on each end.

6" jumper lead with tip plug on one end and banana plug-and-jack combination on other end.

Resistor, fixed, 1 meg, $\frac{1}{4}$ w or $\frac{1}{2}$ w, 1%.

Resistor fixed, 47 Ω , $\frac{1}{2}$ w, 10%.

(3) Connect the oscilloscope power cord to the operating voltage for which the oscilloscope is wired.

(4) Turn on the oscilloscope and allow 20 minutes for warm up and stabilization.

(5) Set the oscilloscope sweep rate and triggering controls to obtain a 0.5 msec/cm free-running sweep.

(6) Preset the W Unit front-panel controls to these settings:

Vc RANGE	+11
COMPARISON VOLTAGE	11.00 (10-10-0)
AC-DC-GND (both inputs)	GND
INPUT ATTEN	1
DISPLAY	A-Vc
MILLIVOLTS/CM	50
VARIABLE (MILLIVOLTS/CM)	CALIB
POSITION	Midrange

PRELIMINARY PROCEDURE

(1) Lay the oscilloscope on its right side. Remove the left side and bottom panels from the oscilloscope. Leave the oscilloscope on its right side.

(2) Insert the W Unit into the oscilloscope plug-in compartment.

CALIBRATION PROCEDURE

1. Adjust Vc CAL R310

- Set the non-loading voltmeter (item 3) to +11 volts.
- Connect the voltmeter between the Vc OUTPUT connector and ground.
- Adjust the Vc CAL control R310 (see Fig. 5-1) for a null reading on the meter.

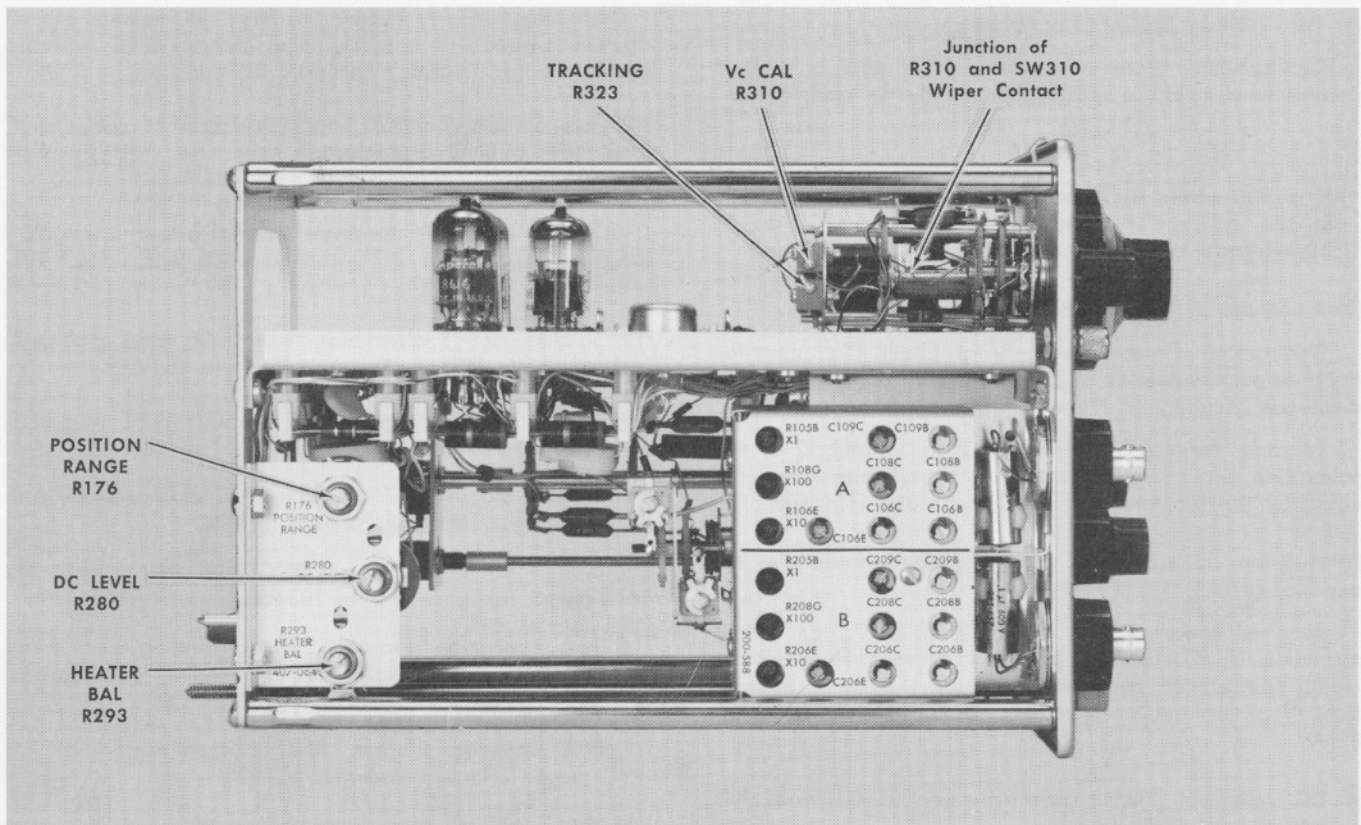

Fig. 5-1. Location of the calibration adjustments (left-side view; securing rod removed for picture).

2. Adjust TRACKING R323

- a. Set the COMPARISON VOLTAGE control to 1.00 (0-10-0).
- b. Set the non-loading voltmeter to +1 volt.
- c. Adjust the TRACKING control R323 (see Fig. 5-1) for a null reading on the meter.

3. Check Tracking of COMPARISON VOLTAGE Control

Using the non-loading voltmeter, check the voltage at each major dial reading of the COMPARISON VOLTAGE control. For example: a voltage of +2 volts should be obtained when the COMPARISON VOLTAGE control is set to 2.00 (1-10-0). Tolerance is $\pm 0.2\%$.

4. Check Vc RANGE Switch

- a. Set the COMPARISON VOLTAGE control to 1.10 (10-10-0).
- b. Set the Vc RANGE switch to +1.1. The Vc OUTPUT connector voltage should be +1.1 volts.
- c. Set the Vc RANGE switch to -1.1 and then to -11. The Vc OUTPUT voltage should measure accordingly.
- d. Set the Vc RANGE switch to 0 and check for zero volts at the Vc OUTPUT connector.
- e. Disconnect the non-loading voltmeter from the Vc OUTPUT connector and ground.

5. Adjust POSITION RANGE R176

NOTE

This is a preliminary adjustment. Final adjustment is made while performing step 6.

- a. Connect a short jumper clip lead from one wiper contact of SW150 (MILLIVOLTS/CM switch) to the other (see Fig. 5-2).
- b. Check that the POSITION control is set to midrange.
- c. Adjust the POSITION RANGE control R176 (see Fig. 5-1) so the trace coincides with graticule center.

6. Adjust DC LEVEL R280

- a. Connect a VOM between the emitter and collector leads of Q184 (see Fig. 5-2).
- b. Adjust the DC LEVEL control R280 (see Fig. 5-1) to obtain a reading of 6 volts on the VOM.
- c. Check that the trace coincides with graticule center. If trace is centered, proceed to step 6-d. If trace is not centered, readjust the POSITION RANGE control to center the trace. If necessary, repeat steps 6-b and 6-c to obtain a 6-volt reading and a centered trace.
- d. Remove the jumper clip lead and disconnect the VOM.

7. Adjust HEATER BAL R293

- a. Preset the VAR BAL and DC BAL front-panel controls to midrange.

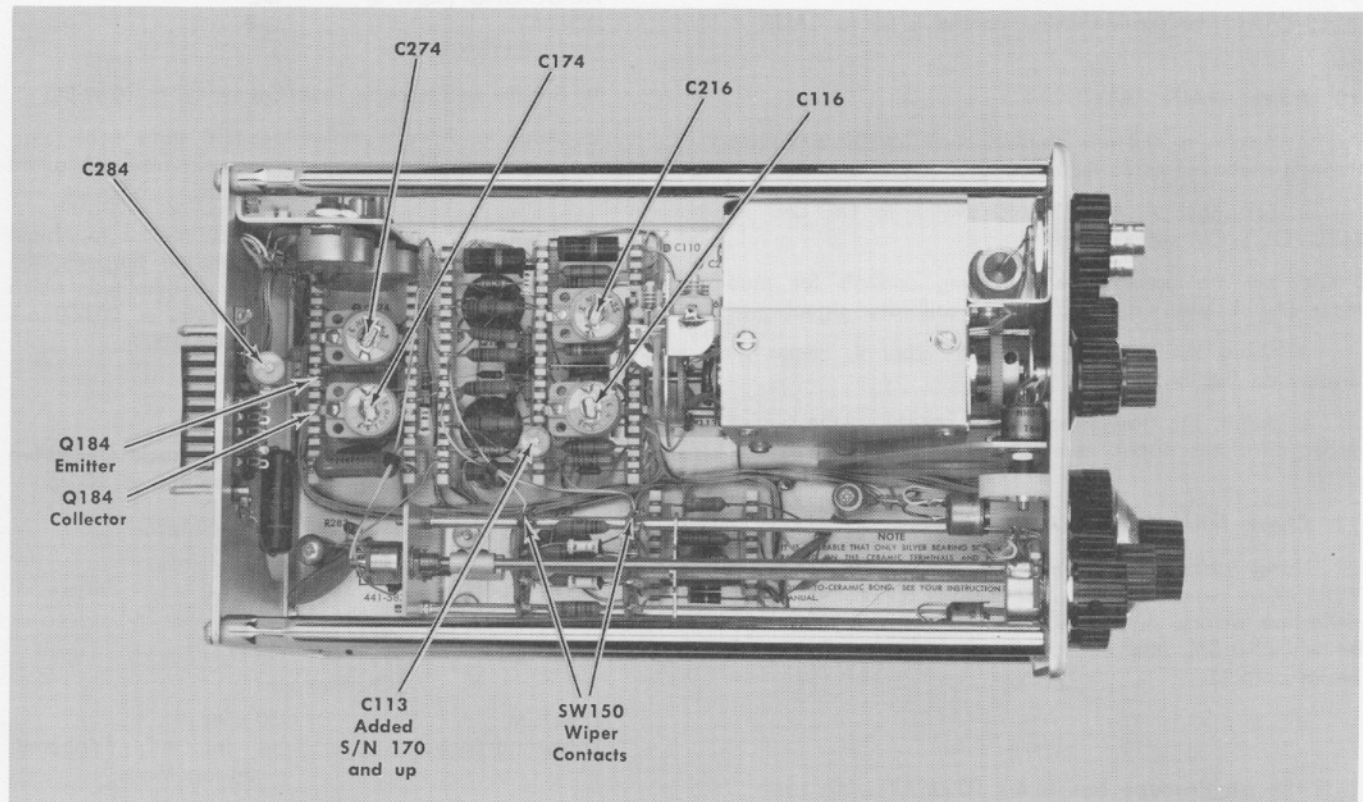

Fig. 5-2. Location of the calibration adjustments and test points (bottom view). Securing rod removed for the illustration.

Calibration—Type W

b. As a preliminary adjustment, slowly adjust the HEATER BAL control R293 (see Fig. 5-1) to center the trace. Due to thermal drift, allow some time for the trace to stabilize to be sure the trace stays centered.

c. As a final adjustment, slowly readjust the HEATER BAL control for minimum trace shift as the VARIABLE control is rotated back and forth.

8. Adjust DC BAL (R127)

a. Set the MILLIVOLTS/CM switch to 1.

b. Adjust the DC BAL control so there is minimum trace shift as the VARIABLE (MILLIVOLTS/CM) control is rotated back and forth.

NOTE

If necessary, use the front-panel VAR BAL (R161) control as a positioning control to keep the trace on the crt.

c. Check that the VARIABLE control is set to CALIB.

9. Adjust VAR BAL (R161)

a. Adjust the VAR BAL control so the trace coincides with graticule center.

b. Repeat steps 8-b and 9-a to obtain minimum trace shift and a centered trace as the VARIABLE control is rotated back and forth.

c. Check that the VARIABLE control is set to CALIB.

10. Adjust GAIN (R157)

a. Apply a 0.2-volt peak-to-peak calibrator signal through a coaxial cable to the A input connector.

b. Set input A AC-DC-GND switch to DC and the MILLIVOLTS/CM switch to 50.

c. Set the oscilloscope triggering controls for automatic (Auto) +Int triggering on the calibrator signal.

d. Using the W Unit POSITION control, center the display on the crt.

e. Adjust the front-panel GAIN control so the vertical deflection of the display is exactly 4 cm peak-to-peak.

11. Check MILLIVOLTS/CM Switch

Using Table 5-1 as a guide, check the remaining MILLIVOLTS/CM switch positions for proper calibrated vertical deflection factors. Amplitude tolerance of the display should be within $\pm 3\%$ plus the tolerance of the amplitude calibrator output.

NOTE

If the oscilloscope has a 4 x 10 cm viewing area, check the deflection factors by using calibrator signal amplitudes that do not overscan the screen.

TABLE 5-1

MILLIVOLTS/CM Switch Position	Amplitude Calibrator Output	Vertical Deflection in cm
20	0.1 v	5
10	50 mv	5
5	20 mv	4
2	10 mv	5
1	5 mv	5

12. Check VARIABLE (MILLIVOLTS/CM) Control

a. Set the MILLIVOLTS/CM switch to 50.

b. Set the amplitude calibrator for an output of 0.2 volt.

c. Turn the control slowly counterclockwise. As the control is turned, the amplitude of the display should increase about 4 mm or more and then decrease. Check for smooth electrical and mechanical operation as the control is turned counterclockwise from the point where the amplitude of the display decreases from 4 cm to 1.6 cm. At 1.6 cm the range of the control is 2.5 to 1 with respect to the 4-cm level.

d. Set the VARIABLE control to CALIB.

e. Disconnect the calibrator signal.

13. Adjust DIFF BAL (R223)

a. Set the W Unit front-panel controls to these settings:
AC-DC-GND (Input B) DC
DISPLAY A-B
MILLIVOLTS/CM 1

b. Set the oscilloscope Time/Cm switch to 10 mSEC.

c. Apply a 20-volt peak-to-peak (10 volts peak referenced to ground) 60-cps sine-wave signal from an audio generator to the A and B input connectors.

d. Adjust the front-panel DIFF BAL control to obtain minimum display amplitude. When adjusted properly, the display amplitude should be 1 cm or less in amplitude which is equal to a common-mode rejection ratio of 20,000-to-1 or better (20 volts divided by 1 mv equals 20,000).

e. Disconnect the audio generator.

14. Adjust C116, C216 and C113—Check Overdrive Recovery—Check Common-Mode Rejection at 20 kc

a. Set the front panel controls as follows:

W Unit	
AC-DC-GND (Input B)	GND
INPUT ATTEN	100
MILLIVOLTS/CM	50
Oscilloscope	
Time/Cm	50 μ Sec
Triggering controls	+ Int, AC, Triggered-Sweep Mode.

At this point in the procedure, the remaining controls should be at the following positions:

W Unit

Vc Range	0
COMPARISON VOLTAGE	10-10-0
AC-DC-GND (Input A)	DC
DISPLAY	A-B
VARIABLE (MILLIVOLTS/CM)	CALIB
POSITION	Midrange
DC BAL	Adjusted for minimum trace shift as VARIABLE control is rotated

b. Apply a 10-kc signal from the Type 105 Square-Wave Generator, or equivalent, through a coaxial cable and 50-ohm termination to the input A connector on the W Unit.

c. Adjust the square-wave generator Output Amplitude control so the display amplitude is 2 cm (10 volts peak-to-peak). Use the Triggering Level control to obtain a stable display.

d. Set the INPUT ATTEN switch to 1 and the MILLI-VOLTS/CM switch to 10.

e. Set the oscilloscope Time/Cm switch to 0.2 μ Sec/Cm. Position the display so the waveform starts at a point one cm from the left edge of the graticule as illustrated in Fig. 5-3a. Check overdrive recovery by observing that the waveform level returns to within 10 mv of its original level in a time duration of 0.3 μ sec (see Fig. 5-3a). If overdrive recovery is greater than 10 mv, set the oscilloscope Time/Cm switch to 2 μ Sec and adjust C116 (see Fig. 5-2) for best flat top (see Fig. 5-3b). The front corner portion of the flat top should be equal amplitude above and below the trailing edge. To check on the accuracy of the adjustment, repeat the first portion of this step (e) to recheck overdrive recovery time.

f. Set the W Unit input A AC-DC-GND switch to GND.

g. Set the oscilloscope Time/Cm switch to 1 mSec and free run the sweep.

h. Position the trace to coincide with graticule center. Set the input A AC-DC-GND switch to DC. Wait 10 seconds and check the position of the trace. The trace should be within 0.5 cm or less from graticule center (see Fig. 5-3c).

i. Using the same setup as described in step 14-b, disconnect the signal from input A and apply the signal to input B. Set the INPUT ATTEN switch to 100, the MILLI-VOLTS/CM switch to 50, the input A AC-DC-GND switch to GND and input B AC-DC-GND switch to DC. Repeat

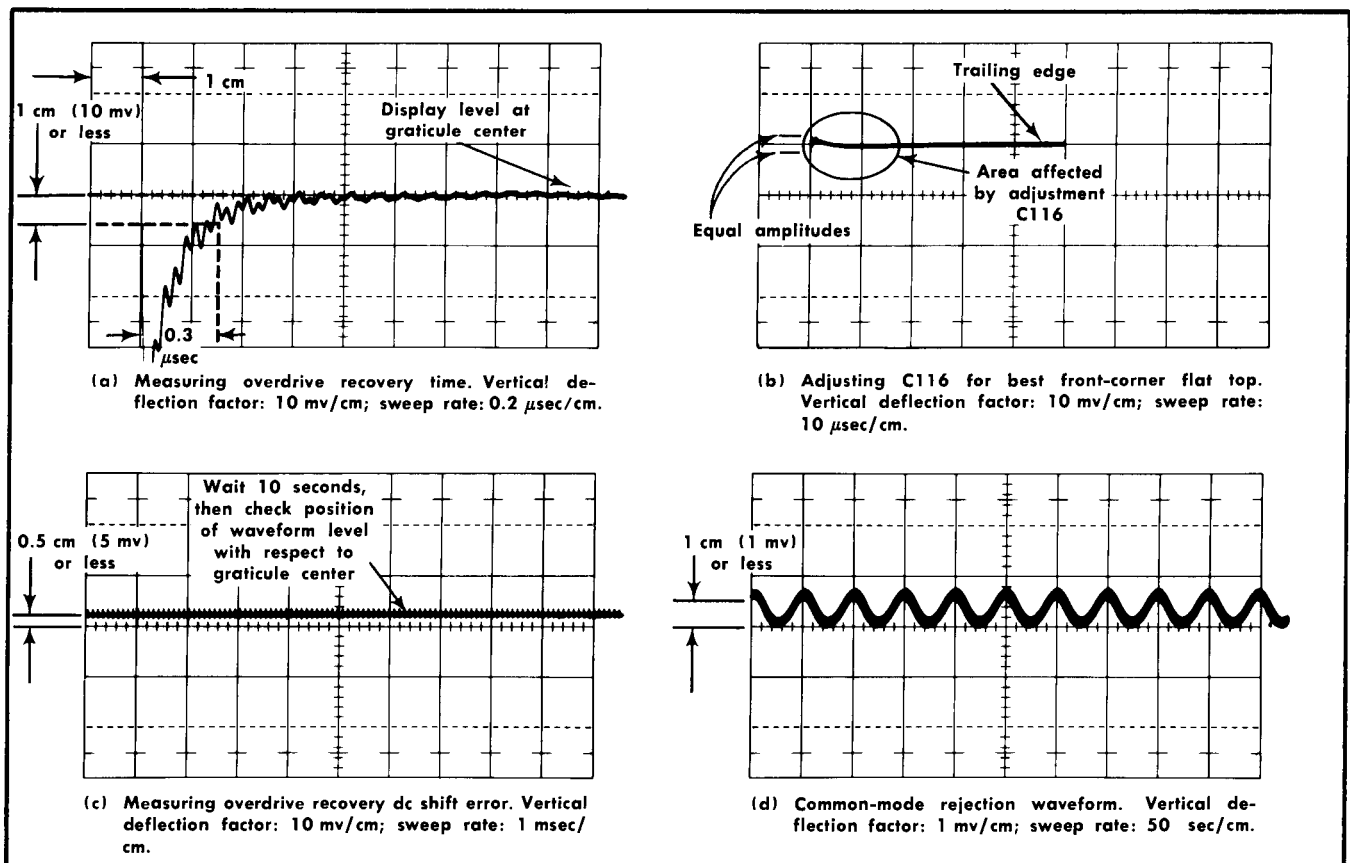

Fig. 5-3. Typical waveforms obtained when performing step 14.

Calibration—Type W

steps 14-c through 14-h with these exceptions: Use —Int triggering. When performing step 14-e, check overdrive recovery on the inverted waveform. If the waveform does not return to within 10 mv of its original level within 0.3 μ sec, adjust C216 (see Fig. 5-2) to obtain the proper display.

j. After completing the procedure for input B, disconnect the square-wave generator.

k. Set the INPUT ATTEN switch to 1000 and the MILLIVOLTS/CM switch to 5. Apply a 20-volt peak-to-peak (10 volts reference to ground) 20-kc sine-wave signal from the audio generator to the input A and B connectors. Use a 42" coaxial cable connect from the audio generator to the T connector. Connect the T connector to channel B. Connect a short jumper coaxial cable from the T connector to input A. Set the oscilloscope Time/Cm switch to .1 mSec and adjust the Triggering Level control to obtain a stable display. The display should be 4 cm (20 volts) in amplitude when the audio generator output amplitude control is set correctly.

l. Set the W Unit controls as follows:

AC-DC-GND (Input A)	DC
INPUT ATTEN	1
MILLIVOLTS/CM	1

m. Check that the DISPLAY switch is set to A-B. Adjust the oscilloscope Triggering Level control, if necessary, to obtain a stable display. Using the W Unit POSITION control, position the display near graticule center. If the display is more than one cm in amplitude for W Units S/N 170 and up, adjust C113 (see Fig. 5-2) so the display is one cm or less in amplitude as shown in Fig. 5-3d. After adjusting C113 and the display is more than one cm, readjust C116 and C216 slightly to reduce the amplitude to the proper amount. In amplitude of one cm or less is a common-mode rejection ratio of 20,000-to-1 or better. If C116 and C216 are readjusted, repeat this entire step (14-a through 14-m).

For W Units below S/N 170 follow a similar procedure given in this step (14-m) but exclude the instruction given for adjusting C113.

15. Check Common-Mode Rejection Ratio at 60 cps

- Set the oscilloscope Time/Cm switch to 10 mSec.
- Set the Triggering controls to + INT and Automatic.
- Set the audio generator for a 60-cps 20-volt peak-to-peak output signal.
- Set the AC-DC-GND switches to AC and the MILLIVOLTS/CM switch to 5.
- The display should be 4 cm or less in amplitude. This is a common-mode rejection ratio of 1,000-to-1 or better.
- Disconnect the audio generator.

16. Check DC Common-Mode Rejection Ratio

- Set the oscilloscope Time/Cm switch to .5 mSec.
- Connect the Vc OUTPUT connector to both A and B input connectors (use the jumper lead with tip plug at the Vc OUTPUT connector).

c. Set the W Unit front-panel controls as follows:

AC-DC-GND (Both A and B)	DC
MILLIVOLTS/CM	1
Vc RANGE	+11
COMPARISON VOLTAGE	10.00 (9-10-0)

d. Note the position of the trace and then set the Vc RANGE switch to 0. Again, note the position of the trace. The difference between trace positions should not be any greater than 0.5 cm to obtain a dc common-mode rejection ratio of 20,000-to-1.

NOTE

If oscillations occur, connect a 47-ohm resistor between the Vc OUTPUT connector and interconnecting lead. Disregard slow trace drift. To double-check the trace positions, set the Vc Range switch to +11 and then back to 0. Note the amount of trace shift.

e. After completing the previous step, note the position of the trace and then set the Vc RANGE switch to —11. Again, note the position of the trace. The difference between the position of the trace when the Vc RANGE switch is set to 0 and when it is set to —11 should not be greater than 0.5 cm.

f. Set the Vc RANGE switch to 0; remove the lead and 47-ohm resistor which connect between the Vc OUTPUT connector and the A and B input connectors.

17. Check Common-Mode Rejection Ratio at 500 kc

- Set the oscilloscope Time/Cm switch to 2 μ Sec.
- Set the W Unit MILLIVOLTS/CM control to 20.
- Apply a 500-kc, 20-volt peak-to-peak signal from the audio generator, or equivalent, to the A and B input connectors of the W Unit.
- The display amplitude should be 2 cm or less in amplitude. This is a common-mode rejection ratio of 500-to-1 or better.

e. Disconnect the audio generator and interconnecting leads.

18. Check Input C.F. Grid Current

- Set the oscilloscope Time/Cm switch to 0.5 mSec.
- Set both AC-DC-GND switches to GND and the MILLIVOLTS/CM switch to 1.
- Using the POSITION control, position the trace to coincide with the center graticule line.
- Set input B AC-DC-GND switch to DC and note the amount of trace shift.
- Set input B AC-DC-GND switch to GND and input A AC-DC-GND switch to DC. Note the amount of trace shift.
- When performing steps 18-d and 18-e, the amount of trace shift should be less than 2 cm which is 2 nano-amperes or less (2 mv divided by 1 meg equals 2 nano-amperes).

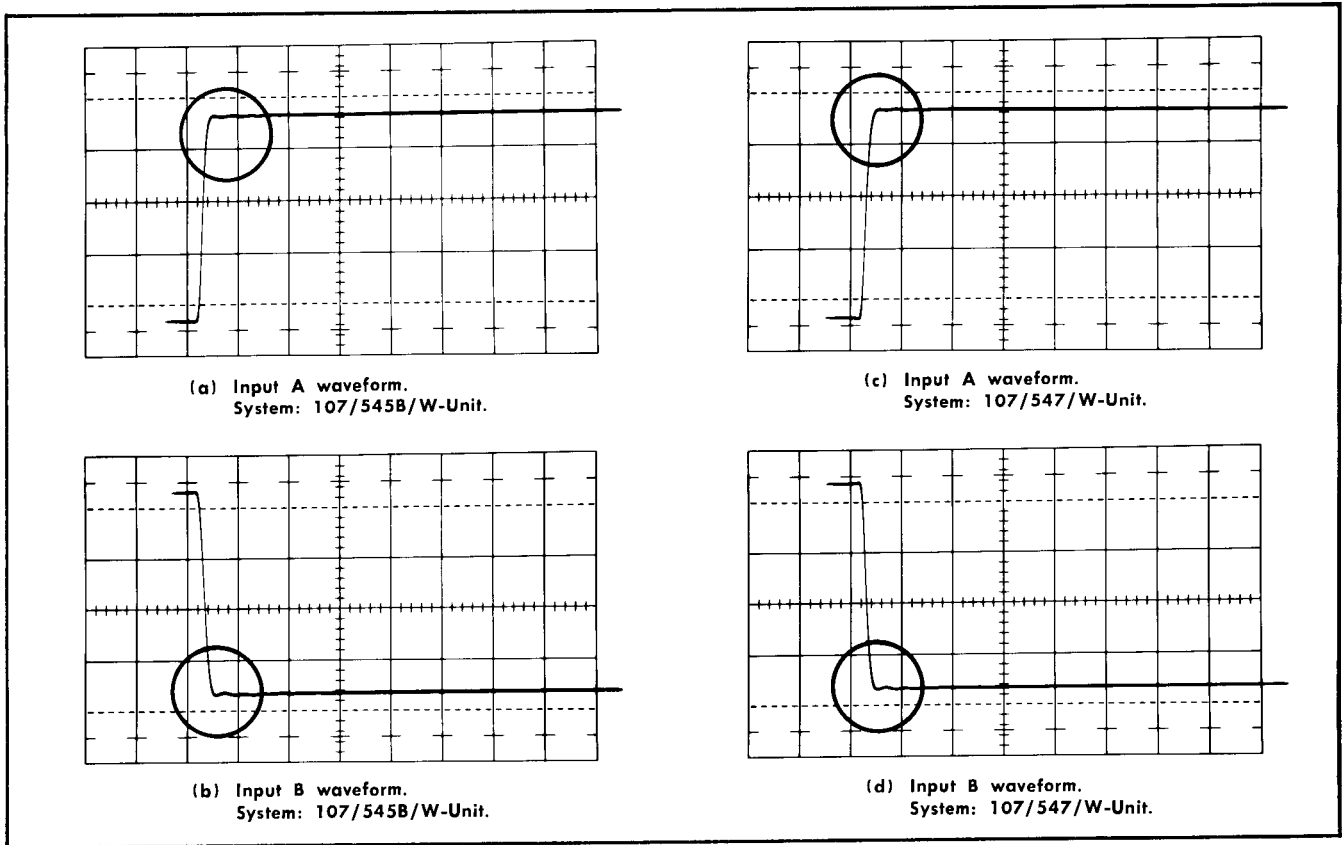

Fig. 5-4. Waveform displays obtained when C174, C274, and C284 are properly adjusted using the system as indicated.

19. Adjust C174, C274 and C284

NOTE

This step adjusts the high-frequency compensation capacitors in the W Unit. Perform this step if the W Unit is being calibrated in an oscilloscope which has a vertical-amplifier risetime of 10 nsec or faster.

- a. Set the oscilloscope Time/Cm switch to 1 μ Sec.
- b. Set the oscilloscope Time/Cm switch to 1 μ Sec. Set the Triggering controls to +INT, AC, and use Triggering-Sweep Mode of operation.
- c. Set the W Unit front-panel controls as follows:

DISPLAY	A-Vc
MILLIVOLTS/CM	50
- d. Apply a 450-kc signal from the Type 107 Square-Wave Generator, or equivalent, through a coaxial cable and a 50-ohm termination (in that order) to the A input connector.
- e. Set the generator output amplitude so the display is 4 cm in amplitude.
- f. Set the oscilloscope Time/Cm switch to 0.1 μ Sec. Set the Level control so the entire rising portion of the positive-going square wave is displayed.
- g. Adjust C174 and C274 (see Fig. 5-2) in equal increments for best leading upper corner on the rising portion

of the square-wave display; that is, for least distorted square-wave response.

- h. Turn on the oscilloscope 5 \times Sweep Magnifier switch so the sweep rate is 0.02 μ sec/cm.
- i. Adjust C284 (see Fig. 5-2) for fastest risetime on the rising portion of the displayed waveform.
- j. Apply the signal to input B.
- k. Set the W Unit front-panel controls to these settings.

AC-DC-GND (Input A)	GND
AC-DC-GND (Input B)	DC
DISPLAY	Vc-B
- l. Turn off the oscilloscope 5 \times Sweep Magnifier; set the triggering controls to — and obtain a stable display.
- m. Slightly readjust C274 for best lower corner on the negative-going square-wave display.
- n. Set the W Unit front-panel controls as follows:

AC-DC-GND (Input A)	DC
AC-DC-GND (Input B)	GND
DISPLAY	A-Vc
- o. Apply the 450-kc signal to input A.
- p. Set the oscilloscope triggering controls for +Int triggering and obtain a stable display.
- q. Slightly readjust C174 for best upper corner.

Calibration—Type W

r. Repeat steps 19-i through 19-o and check the A and B displays. Front corner aberrations should not exceed ± 1 mm. If it is necessary to improve the transient response, slightly readjust C174, C274 and C284 to obtain a best compromise of transient response and risetime (see Fig. 5-4).

- s. Disconnect the square-wave generator.
- t. Set the oscilloscope in its upright position.

20. Adjust R106E (Input A 10X Attenuator)

a. Set the W Unit front-panel controls as follows:

AC-DC-GND (Input A)	DC
AC-DC-GND (Input B)	GND
INPUT ATTEN	10
DISPLAY	A-Vc
MILLIVOLTS/CM	1
COMPARISON VOLTAGE	Fully clockwise (10-10-past 0)

b. Set the oscilloscope Time/Cm switch to 0.5 mSec and free run the trace.

c. Connect a short jumper lead from the A input connector to the junction of R310 and the wiper contact of SW310 (see Fig. 5-1).

d. Connect a short jumper lead from the A input connector to the Precision Dc Divider Voltage Input connector (item 20).

e. Connect a 1 meg (1%) resistor from the Precision Dc Divider Voltage Output connector to the Gnd connector.

f. Connect a short jumper lead from the Precision Dc Divider Gnd connector to the W Unit ground binding post.

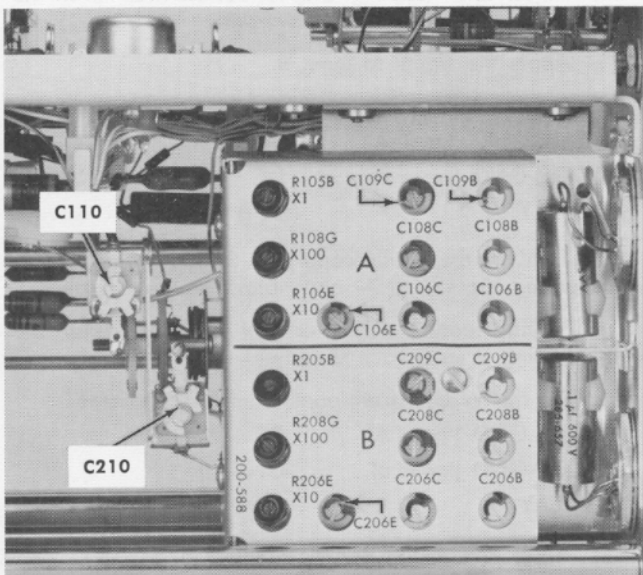

Fig. 5-5. Location of input time constant standardization and attenuator adjustments.

g. Connect a short jumper lead with a tip plug from the Precision Dc Divider Voltage Output connector to the Vc OUTPUT connector and set the 10:1—100:1 switch to 10:1.

h. Using the POSITION control, position the trace to coincide with graticule center.

NOTE

From time to time it may be necessary to check the dc balance of the W Unit by checking the DC BAL adjustment. If necessary, readjust the DC BAL control to obtain minimum trace shift as the MILLIVOLTS/CM switch position is changed and then returned to its former position.

i. Set the COMPARISON VOLTAGE control outer (switch) knob to a position between 10 and 9 detent positions to internally disconnect the comparison voltage from the Vc OUTPUT connector. (However, externally the divider voltage will be applied via the jumper to the Vc OUTPUT connector. This voltage is then internally applied from the connector through the DISPLAY switch to the B input grid side of the W Unit amplifier.)

j. Set the Vc RANGE switch to +11.

k. Adjust R106E (see Fig. 5-5) to return the trace to graticule center.

21. Adjust R108G (Input A 100X Attenuator)

a. Set the Vc RANGE switch to 0 and COMPARISON VOLTAGE control outer knob to 10.

b. Set the INPUT ATTEN switch to 100.

c. Set the Precision Dc Divider 10:1—100:1 switch to 100:1.

d. Check that the trace is centered. If necessary, use the DC BAL control to position the trace to coincide with graticule center.

e. Set the COMPARISON VOLTAGE control outer knob between the 10 and 9 detent positions; set the Vc RANGE switch to +11.

f. Adjust R108G (see Fig. 5-5) to position the trace to coincide with graticule center.

g. Set the Vc RANGE switch to 0 and the COMPARISON VOLTAGE control outer knob to 10.

h. Leave the jumper connected that connects from the A input connector to the junction of R310 and the wiper contact of SW310. Disconnect all other jumpers and connections to disconnect the Precision Dc Divider from the W Unit.

22. Check Input A 100X Attenuator

a. Set the W Unit controls as follows:

COMPARISON VOLTAGE	0.011 v (0-0-11)
INPUT ATTEN	1000

b. Check that the trace is centered.

c. Set the Vc RANGE switch to +11.

d. Check that the trace does not move more than 0.2 cm when switching the Vc RANGE switch from the +1.1 position to the 0 position.

e. Check that the Vc RANGE switch is set to 0.

23. Adjust R105B (Input A 1X Attenuator)

- a. Insert a 1 meg (1%) resistor between the jumper and the A input connector.
- b. Set the W Unit controls as follows:

INPUT ATTEN	10
Vc RANGE	+1.1
- c. Rotate the COMPARISON VOLTAGE control to position the trace to graticule center. The control setting will be near +0.55 v (5-5-0). Leave the control at this setting until step 23-g is completed.
- d. Connect a non-loading voltmeter between input A connector and ground.
- e. Set the non-loading voltmeter to obtain a null reading (at about 5.5 volts).
- f. Set the INPUT ATTEN switch to 1 and Vc RANGE switch to +11.
- g. Adjust R105B (see Fig. 5-5) to obtain a null reading on the non-loading voltmeter.
- h. Disconnect the voltmeter.

24. Adjust R206E (Input B 10X Attenuator)

- a. Set the W Unit controls as follows:

Vc RANGE	0
COMPARISON VOLTAGE	Fully clockwise (10-10-past 0)
AC-DC-GND (Input A)	GND
AC-DC-GND (Input B)	DC
INPUT ATTEN	10
DISPLAY	Vc-B
- b. Remove the 1-meg resistor and connect the jumper lead to the B input connector. With the resistor removed, the jumper lead now connects between the B input connector and the junction of R310 and the wiper contact of SW310.
- c. Connect a short jumper lead from the B input connector to the Precision Dc Divider Voltage Input connector.
- d. Repeat steps 20-e through 20-j. (The divider voltage is now applied via the Vc OUTPUT connector to the A input grid side of the W Unit amplifier.)
- e. Adjust R206E (see Fig. 5-5) to return the trace to graticule center.

25. Adjust R208G (Input B 100X Attenuator)

- a. Repeat steps 21-a through 21-c.
- b. With all connections remaining as in step 24, check that the trace is centered. If necessary, use the DC BAL control to position the trace to coincide with graticule center.
- c. Set the COMPARISON VOLTAGE control outer knob between the 10 and 9 detent positions; set the Vc RANGE switch to +11.
- d. Adjust R208G (see Fig. 5-5) to center the trace.

- e. Set the Vc RANGE switch to 0 and the COMPARISON VOLTAGE outer knob to 10.

- f. Leave the jumper connected that connects from the B input connector to the junction of R310 and the wiper contact of SW310. Disconnect all other jumpers and connections to disconnect the Precision Dc Divider from the W Unit.

26. Check Input B 1000X Attenuator

Repeat steps 22-a through 22-e.

27. Adjust R205B (Input B 1X Attenuator)

- a. Insert the 1-meg resistor between the +11-volt jumper lead and the B input connector.
- b. Set the W Unit controls as follows:

COMPARISON VOLTAGE	5-5-0
INPUT ATTEN	10
- c. Check that the trace is centered. If necessary use the DC BAL control to center the trace.
- d. Set the Vc RANGE switch to +1.1.
- e. Set the COMPARISON VOLTAGE control to center the trace. Leave the COMPARISON VOLTAGE control at this setting until step 27-i is completed.
- f. Connect the non-loading voltmeter between the B input connector and ground.
- g. Set the non-loading voltmeter to obtain a null reading (about 5.5 volts).
- h. Set the INPUT ATTEN switch to 1 and Vc RANGE switch to +11.
- i. Adjust R205B (see Fig. 5-5) to obtain a null reading on the non-loading voltmeter.

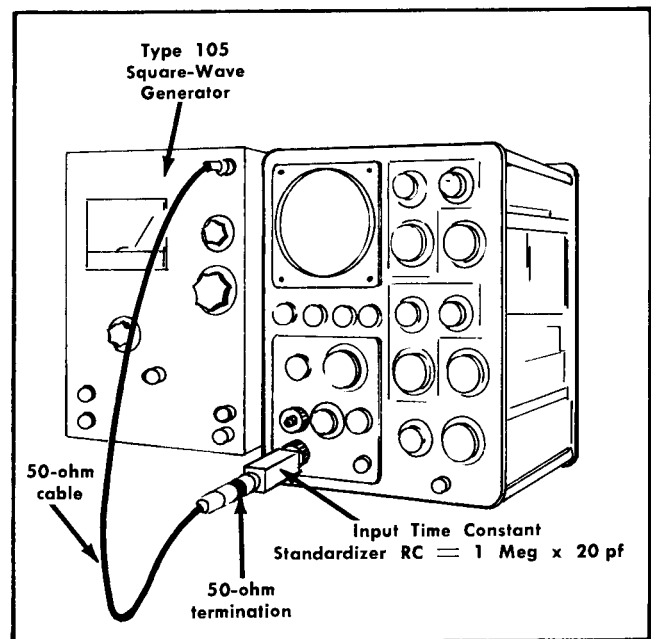

Fig. 5-6. Setup for performing step 28.

Calibration—Type W

- j. Set the Vc RANGE switch to 0.
- k. Disconnect the voltmeter, resistor, and jumper lead.

28. Adjust C210 (Input B 1X Input Time Constant Standardization)

- a. Set the MILLIVOLTS/CM switch to 50.
- b. Apply a 1-kc signal from the Type 105 Square-Wave Generator, or equivalent, through a coaxial cable, a 50-ohm termination and a 1-meg \times 20-pf input time constant standardizer (in that order) to the B input connector (see Fig. 5-6).
- c. Set the square-wave generator output amplitude so the display is about 4 cm in amplitude.
- d. Set the oscilloscope triggering controls for —Int stable triggering on the signal.

NOTE

Use the W Unit POSITION control in this and succeeding steps for centering the display for best viewing.

- e. Adjust C210 (see Fig. 5-5) for best lower front corner on the square-wave display (see Fig. 5-7a). Figs. 5-7b and 5-7c show effect obtained when C210 is incorrectly adjusted.

29. Adjust C110 (Input A 1X Input Time Constant Standardization)

- a. Disconnect the signal from input B and apply it to the A input connector.
- b. Set the W Unit controls as follows:

AC-DC-GND (Input A)	DC
AC-DC-GND (Input B)	GND
DISPLAY	A-Vc
- c. Set the oscilloscope triggering controls for +Int triggering on the signal.
- d. Adjust C110 (see Fig. 5-5) for best upper front corner on the square-wave display (see Fig. 5-8).

30. Adjust Input Attenuator High-Frequency Compensation

- a. Remove the input time-constant standardizer.
- b. Connect the square-wave generator signal through the cable, termination, and a T connector (in that order) to the A input connector.
- c. Connect a short coax jumper cable from the T connector to the B input connector.
- d. Using Table 5-2 as a guide, perform the adjustments listed in the table for input A; that is, C106C, C106E, C108C, and C109C. Use the generator amplitude control to maintain 4 cm of deflection for the display. Fig. 5-9a shows the correct display; Figs. 5-9b and 5-9c show incorrect displays.

TABLE 5-2
Attenuator High-Frequency Compensation

INPUT ATTEN Switch Setting	MILLI-VOLTS/CM Switch Setting	Adjustment (See Fig. 5-5)	Adjust For
10	50	C106C first, then C106E*	Best upper front corner (see Fig. 5-9a.)
100	20	C108C	
1000	2	C109C	
1000	2	C209C	Best lower front corner. Similar display to that obtained through input A.
100	20	C208C	
10	50	C206C first, then C206E*	

*If C106E or C206E do not have sufficient range for proper adjustment, center the adjustment and repeat the procedure.

- d. After completing the adjustments for input A, set the W Unit controls as follows:

AC-DC-GND (Input A)	GND
AC-DC-GND (Input B)	DC
DISPLAY	Vc-B

- e. Using Table 5-2 as a guide, adjust C209C, C208C, C206C, and C206E. When making the adjustments, set the AC-DC-GND switches to opposite positions and the DISPLAY switch to A-Vc to compare the display obtained for input B to the display obtained for input A. When the adjustments are properly made, the displays for the two inputs should appear very similar to each other.

31. Adjust Input Attenuator Time Constant

- a. Set the W Unit controls as follows:

AC-DC-GND (Input A)	DC
AC-DC-GND (Input B)	GND
DISPLAY	A-Vc
- b. Remove the T connector and short coax jumper cable. In their place insert the input time constant standardizer and apply the signal to input A.
- c. Adjust the square-wave generator output amplitude so the display is 4 cm in amplitude.
- d. Using Table 5-3 as a guide, adjust C106B, C108B, and C109B. Maintain 4 cm of deflection.

TABLE 5-3
Attenuation Time-Constant Standardization

INPUT ATTEN Switch Setting	MILLI-VOLTS/CM Switch Setting	Adjustments (See Fig. 5-5)	Adjust For
10	50	C106B	Best upper front corner similar to Fig. 5-8.
100	10	C108B	
1000	1	C109B	
1000	1	C209B	Best lower front corner similar to Fig. 5-7a.
100	10	C208B	
10	50	C206B	

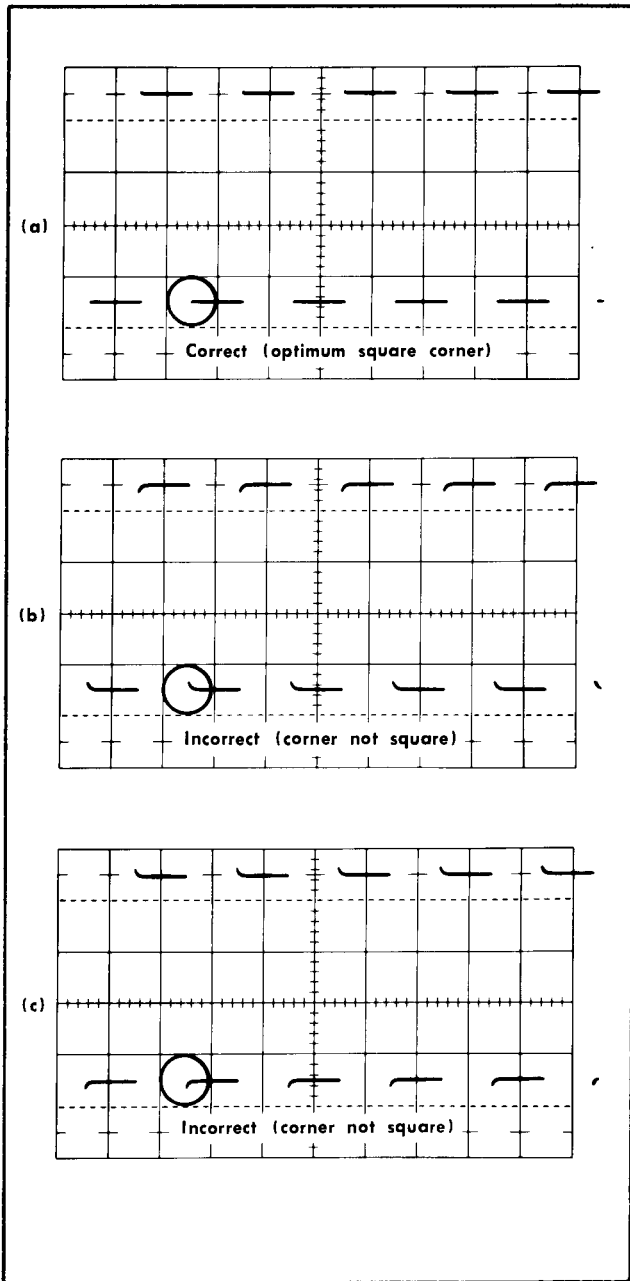

Fig. 5-7. Standardizing the 1X input time constant of input B.

e. After completing the input A adjustments, set the W Unit controls as follows:

AC-DC-GND (Input A)	GND
AC-DC-GND (Input B)	DC
DISPLAY	V _c -B

f. Disconnect the signal from input A and apply the signal to input B.

g. Using Table 5-3 as a guide, adjust C209B, C208B, and C206B.

h. Disconnect the signal from input B and turn off the square-wave generator.

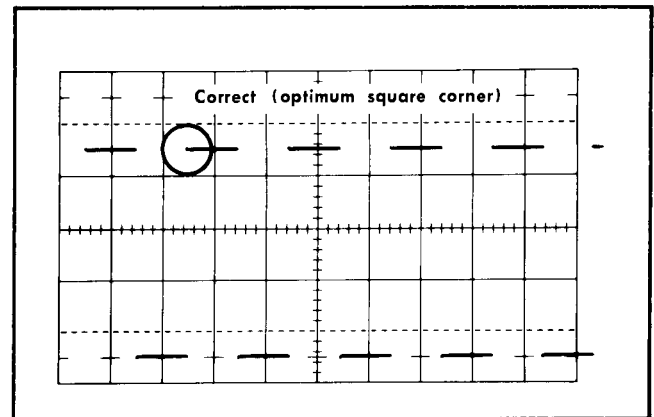

Fig. 5-8. Standardizing the 1X input time constant of input A.

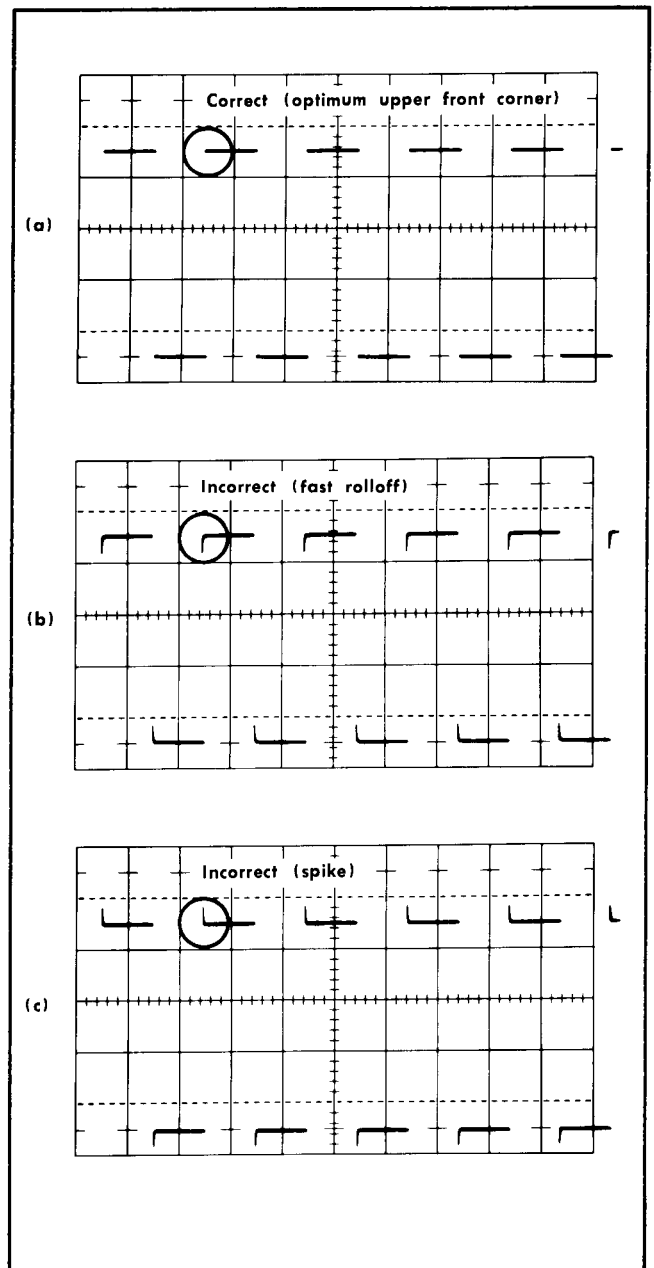

Fig. 5-9. Frequency-compensating the attenuators.

Calibration—Type W

32. Check Frequency Response

a. Set the W Unit controls as follows:

INPUT ATTEN	1
MILLIVOLTS/CM	50

b. Set the oscilloscope Time/Cm switch to 0.1 mSec and free run the sweep.

c. Apply a 50-kc signal from the Type 190B Constant-Amplitude Signal Generator, or equivalent, to the B input connector.

d. Adjust the generator amplitude control to obtain 4 cm of vertical deflection as a reference. If the generator signal cannot be attenuated sufficiently using the generator attenuator, use a 10× attenuator to connect between the B input connector and the generator output.

e. Set the sine-wave generator output frequency to the frequency which is 30% down-point for the oscilloscope/W Unit combination. Refer to the Characteristics section to find the passband of the system.

NOTE

The Type 190B generator maintains a constant-amplitude output signal automatically. If the generator you are using does not maintain a constant-

amplitude output, the generator output should be monitored and adjusted to the correct output level used as the reference. To monitor the output, use a wide-band test oscilloscope having a flat frequency response equal to or better than the frequency response (includes 30% down-point) of the oscilloscope/W Unit combination under test.

f. At the frequency used in the previous step, check for at least 2.8 cm of vertical deflection on the oscilloscope used with the W Unit. This is the 30% down-point for the combination you are checking.

g. Check frequency response of each MILLIVOLTS/CM switch position. Compare your results with those listed in the Characteristics section.

h. Set the W Unit controls as follows:

AC-DC-GND (Input A)	DC
AC-DC-GND (Input B)	GND
DISPLAY	A-Vc

i. Apply the signal to input A and check the frequency response for each MILLIVOLTS/CM switch position in the same manner as was done for input B.

j. Disconnect the sine-wave generator.

SECTION 6

PARTS LIST and DIAGRAMS

PARTS ORDERING INFORMATION

Replacement parts are available from or through your local Tektronix Field Office.



Changes to Tektronix instruments are sometimes made to accommodate improved components as they become available, and to give you the benefit of the latest circuit improvements developed in our engineering department. It is therefore important, when ordering parts, to include the following information in your order: Part number including any suffix, instrument type, serial number, and modification number if applicable.

If a part you have ordered has been replaced with a new or improved part, your local Tektronix Field Office will contact you concerning any change in part number.

ABBREVIATIONS AND SYMBOLS

a or amp	amperes	mm	millimeter
BHS	binding head steel	meg or M	megohms or mega (10 ⁶)
C	carbon	met.	metal
cer	ceramic	μ	micro, or 10 ⁻⁶
cm	centimeter	n	nano, or 10 ⁻⁹
comp	composition	Ω	ohm
cps	cycles per second	OD	outside diameter
crt	cathode-ray tube	OHS	oval head steel
CSK	counter sunk	p	pico, or 10 ⁻¹²
dia	diameter	PHS	pan head steel
div	division	piv	peak inverse voltage
EMC	electrolytic, metal cased	plstc	plastic
EMT	electrolytic, metal tubular	PMC	paper, metal cased
ext	external	poly	polystyrene
f	farad	Prec	precision
F & I	focus and intensity	PT	paper tubular
FHS	flat head steel	PTM	paper or plastic, tubular, molded
Fil HS	fillister head steel	RHS	round head steel
g. or G	giga, or 10 ⁹	rms	root mean square
Ge	germanium	sec	second
GMV	guaranteed minimum value	Si	silicon
h	henry	S/N	serial number
hex	hexagonal	t or T	tera, or 10 ¹²
HHS	hex head steel	TD	toroid
HSS	hex socket steel	THS	truss head steel
HV	high voltage	tub.	tubular
ID	inside diameter	v or V	volt
incd	incandescent	Var	variable
int	internal	w	watt
k or K	kilohms or kilo (10 ³)	w/	with
kc	kilocycle	w/o	without
m	milli, or 10 ⁻³	WW	wire-wound
mc	megacycle		

SPECIAL NOTES AND SYMBOLS

X000	Part first added at this serial number.
000X	Part removed after this serial number.
*000-000	Asterisk preceding Tektronix Part Number indicates manufactured by or for Tektronix, or reworked or checked components.
Use 000-000	Part number indicated is direct replacement.
	Internal screwdriver adjustment.
	Front-panel adjustment or connector.

EXPLODED VIEW

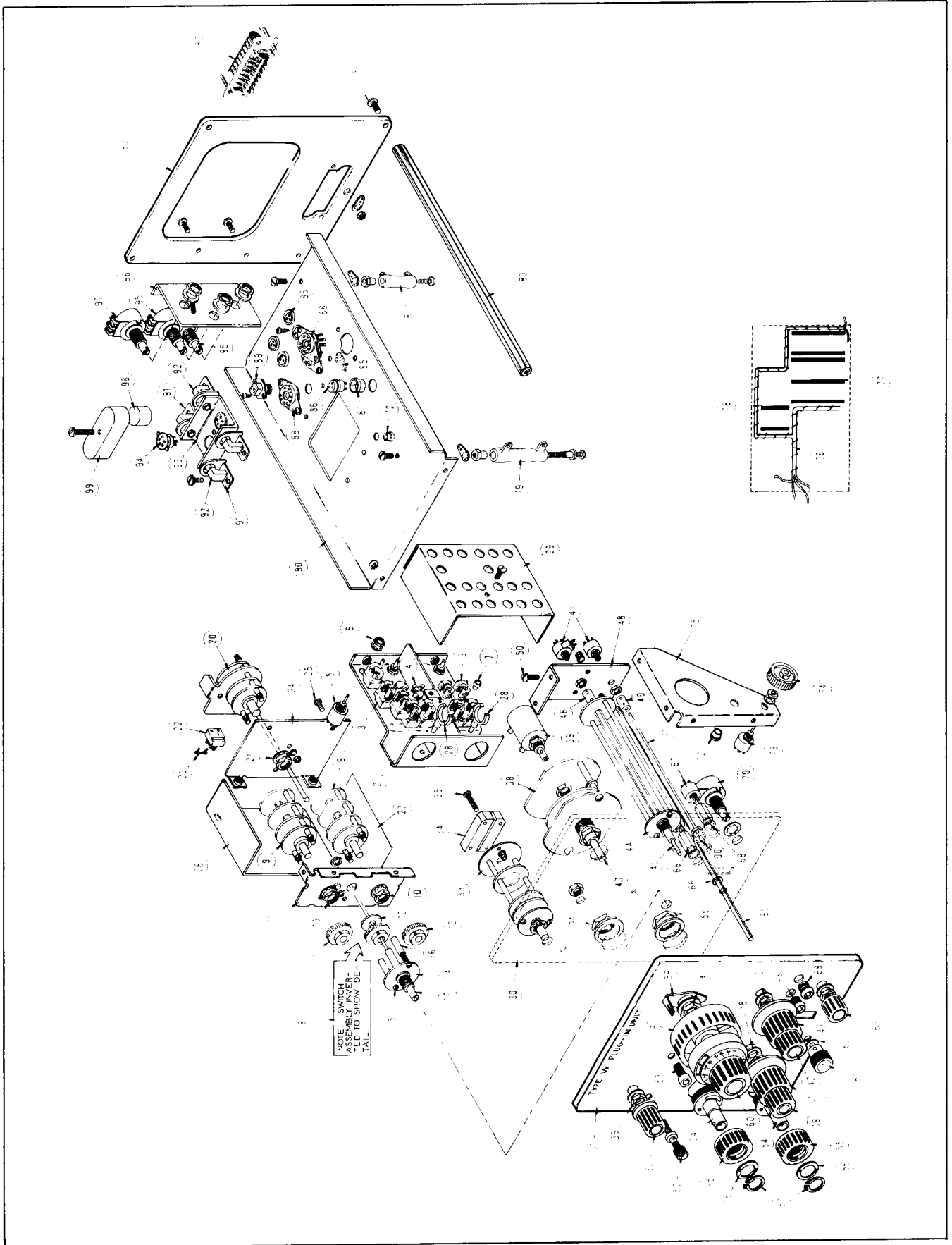

EXPLODED VIEW

REF. NO.	PART NO.	SERIAL/MODEL NO.		QTY.	DESCRIPTION
		EFF.	DISC.		
1	366-0142-00			1	KNOB, large charcoal—INPUT ATTEN
	213-0004-00			-	knob includes:
				1	SCREW, set, 6-32 x 3/16 inch HSS
2	644-0009-00	100	869	1	ASSEMBLY, attenuator switch (see ref. #18)
	644-0009-01	870		1	ASSEMBLY, attenuator switch (see ref. #18)
				-	attenuator assembly includes:
	610-0130-00			1	ASSEMBLY, attenuator chassis
				-	assembly includes:
	441-0586-00			1	CHASSIS, attenuator
3				14	CAPACITOR
				-	mounting hardware for each: (not included w/cap. alone)
4	214-0456-00			1	FASTENER, delrin
5				6	POT
6				-	mounting hardware for each: (not included w/pot alone)
	210-0223-00			1	LUG, solder, 1/4 inch
	210-0940-00			1	WASHER, 1/4 ID x 3/8 inch OD
	210-0562-00			1	NUT, hex, 1/4-40 x 5/16 inch
7	358-0136-00			10	BUSHING, teflon
8	262-0680-00	100	869	1	SWITCH, wired—INPUT ATTEN
	262-0680-01	870		1	SWITCH, wired—INPUT ATTEN
				-	switch includes:
9	260-0634-00			2	SWITCH, unwired—INPUT ATTEN
10				-	mounting hardware for each: (not included w/switch alone)
	210-0012-00	100	170X	1	LOCKWASHER, internal, 3/8 x 1/2 inch
	210-0413-00			1	NUT, hex, 3/8-32 x 1/2 inch
11	337-0671-00			1	SHIELD, switch mounting
12	214-0461-00			3	GEAR, assembly
				-	each gear includes:
	213-0020-00			1	SCREW, set, 6-32 x 1/8 inch HSS
13	210-0913-00			2	WASHER, phenolic, 1/4 ID x 5/8 inch OD
14	387-0985-00			1	PLATE, switch, front
				-	mounting hardware: (not included w/plate alone)
15	211-0018-00			2	SCREW, 4-40 x 7/8 inch RHS
16	166-0106-00			2	TUBE, spacing
	210-0586-00			2	NUT, keps, 4-40 x 1/4 inch
17	384-0325-00			1	ROD, shaft drive gear
18				-	mounting hardware: (not included w/attenuator assembly)
	210-0840-00			1	WASHER, .390 ID x 3/16 inch OD
	210-0413-00			1	NUT, hex, 3/8-32 x 1/2 inch
19	366-0031-00			1	KNOB, small red—DISPLAY
				-	knob includes:
	213-0004-00			1	SCREW, set, 6-32 x 3/16 inch HSS

EXPLODED VIEW (Cont'd)

REF. NO.	PART NO.	SERIAL/MODEL NO.		QTY.	DESCRIPTION
		EFF.	DISC.		
20	262-0679-00			1	SWITCH, wired—DISPLAY (see ref. #25)
	- - - - -			-	switch includes:
	260-0635-00			1	SWITCH, unwired—DISPLAY
	- - - - -			-	mounting hardware: (not included w/switch alone)
21	210-0012-00			1	LOCKWASHER, internal, 3/8 x 1/2 inch
	210-0413-00			1	NUT, hex, 3/8-32 x 1/2 inch
22	- - - - -			2	CAPACITOR
	- - - - -			-	mounting hardware for each: (not included w/capacitor alone)
23	214-0456-00			1	FASTENER, delrin
24	337-0670-00			1	SHIELD, switch mounting
25	- - - - -			-	mounting hardware: (not included w/switch)
	211-0008-00			2	SCREW, 4-40 x 1/4 inch BHS
26	200-0589-00			1	COVER, attenuator
	- - - - -			-	mounting hardware: (not included w/cover)
	211-0007-00			6	SCREW, 4-40 x 3/16 inch BHS
27	200-0593-00			1	COVER, attenuator
	- - - - -			-	mounting hardware: (not included w/cover)
	211-0007-00			2	SCREW, 4-40 x 3/16 inch BHS
28	352-0068-00	100	1219X	2	HOLDER, delrin
29	200-0588-00			1	COVER, attenuator
	- - - - -			-	mounting hardware: (not included w/cover)
	211-0007-00			1	SCREW, 4-40 x 3/16 inch BHS
30	387-0979-00			1	PLATE, front sub-panel
31	333-0834-00			1	PANEL, front
32	366-0173-00			1	KNOB, charcoal—Vc RANGE
	- - - - -			-	knob includes:
	213-0004-00			1	SCREW, set, 6-32 x 3/16 inch HSS
33	262-0678-00			1	SWITCH, wired—Vc RANGE (see ref. #36)
	- - - - -			-	switch includes:
	260-0633-00			1	SWITCH, unwired—Vc RANGE
34	- - - - -			2	POT
	- - - - -			-	mounting hardware for each: (not included w/pot alone)
35	211-0034-00			2	SCREW, 2-56 x 1/2 inch RHS
	210-0001-00			2	LOCKWASHER, internal, #2
	210-0405-00			2	NUT, hex, 2-56 x 3/16 inch
36	- - - - -			-	mounting hardware: (not included w/switch)
	210-0012-00			1	LOCKWASHER, internal, 3/8 x 1/2 inch
	210-0840-00			1	WASHER, .390 ID x 3/16 inch OD
	210-0413-00			1	NUT, hex, 3/8-32 x 1/2 inch
37	366-0279-00			1	KNOB, large charcoal—COMPARISON VOLTAGE (Vc)
	- - - - -			-	knob includes:
	213-0020-00			2	SCREW, set, 6-32 x 1/8 inch HSS

EXPLODED VIEW (Cont'd)

REF. NO.	PART NO.	SERIAL/ MODEL NO.		QTY.	DESCRIPTION
		EFF.	DISC.		
38	262-0677-00			1	SWITCH, wired—COMPARISION VOLTAGE (Vc) (see ref. #41)
	- - - - -			-	switch includes:
	260-0631-00	100	1629	1	SWITCH, unwired—COMPARISION VOLTAGE (Vc)
	260-0777-00	1630		1	SWITCH, unwired—COMPARISION VOLTAGE (Vc)
39	- - - - -			1	POT
	- - - - -			-	mounting hardware: (not included w/pot alone)
	210-0413-00			1	NUT, hex, $\frac{3}{8}$ -32 x $\frac{1}{2}$ inch
	426-0289-00	X1630		1	MOUNT, plastic
	210-0801-00	X1630		2	WASHER, flat, 5s x $\frac{9}{32}$ inch
	211-0008-00	X1630		2	SCREW, 4-40 x $\frac{1}{4}$ inch, PHS
40	384-0320-00			1	ROD, shaft
41	- - - - -			-	mounting hardware: (not included w/switch)
	210-0049-00			1	LOCKWASHER, internal, $\frac{5}{8}$ inch ID
	210-0579-00			1	NUT, hex, $\frac{5}{8}$ -24 x $\frac{3}{4}$ inch
42	366-0031-00			1	KNOB, small red—VARIABLE
	- - - - -			-	knob includes:
	213-0004-00			1	SCREW, set, 6-32 x $\frac{3}{16}$ inch HSS
43	366-0142-00			1	KNOB, large charcoal—MILLIVOLT/CM
	- - - - -			-	knob includes:
	213-0004-00			1	SCREW, set, 6-32 x $\frac{3}{16}$ inch HSS
44	262-0676-00			1	SWITCH, wired—MILLIVOLTS/CM (see ref. #50 & 51)
	- - - - -			-	switch includes:
	260-0632-00			1	SWITCH, unwired—MILLIVOLTS/CM
	- - - - -			-	mounting hardware: (not included w/switch alone)
	210-0004-00			2	LOCKWASHER, internal, #4
	210-0406-00			2	NUT, hex, 4-40 x $\frac{3}{16}$ inch
45	384-0146-00	100	2229	1	ROD, extension
	384-0409-00	2230		1	ROD, extension
46	376-0029-00			1	COUPLING, shaft
	- - - - -			-	coupling includes:
	213-0075-00			2	SCREW, set, 4-40 x $\frac{3}{32}$ inch
47	- - - - -			2	POT
	- - - - -			-	mounting hardware for each: (not included w/pot alone)
	210-0940-00			1	WASHER, $\frac{1}{4}$ ID x $\frac{3}{8}$ inch OD
	210-0562-00			1	NUT, hex, $\frac{1}{4}$ -40 x $\frac{5}{16}$ inch
48	407-0065-00			1	BRACKET, pot
49	376-0039-00			1	COUPLING, shaft
	- - - - -			-	coupling includes:
	213-0075-00			2	SCREW, set, 4-40 x $\frac{3}{32}$ inch
	- - - - -			-	mounting hardware: (not included w/switch)
50	211-0504-00			2	SCREW, 6-32 x $\frac{1}{4}$ inch PHS
51	210-0012-00			1	LOCKWASHER, internal, $\frac{3}{8}$ x $\frac{1}{2}$ inch
	210-0840-00			1	WASHER, .390 ID x $\frac{9}{16}$ inch OD
	210-0413-00			1	NUT, hex, $\frac{3}{8}$ -32 x $\frac{1}{2}$ inch
52	129-0035-00			1	POST, ground, assembly
	- - - - -			-	post includes:
	355-0507-00			1	STEM, adapter
	200-0103-00			1	CAP
	210-0455-00			1	NUT, hex, $\frac{1}{4}$ -28 x $\frac{3}{8}$ inch
	210-0046-00			1	LOCKWASHER, internal, .261 ID x .400 inch OD
53	136-0163-00			1	SOCKET, tip jack (w/mounting nut)

EXPLODED VIEW (Cont'd)

REF. NO.	PART NO.	SERIAL/MODEL NO.		QTY.	DESCRIPTION
		EFF.	DISC.		
54	260-0603-00			2	SWITCH, unwired—AC-DC-GND (see ref. #58)
	- - - - -			-	each switch includes:
55	366-0274-00			1	KNOB, charcoal—AC-DC-GND
56	210-0951-00			1	WASHER, locating
57	354-0179-00			1	RING, retaining
	214-0240-00			1	SPRING, compression (not shown)
	214-0274-00			1	BALL, stainless steel (not shown)
58	- - - - -			-	mounting hardware for each: (not included w/switch)
	210-0047-00			1	LOCKWASHER, internal, 1.110 OD x .880 inch ID
	210-0568-00			1	NUT, mounting, 7/8-32 x 1 1/8 inches
59	214-0488-00			1	LUG, pot indicator index
60	331-0091-00			1	DIAL, w/charcoal knob
61	366-0125-00			1	KNOB, gray
	- - - - -			-	knob includes:
	213-0004-00			1	SCREW, set, 6-32 x 3/16 inch HSS
62	210-0894-00			1	WASHER, polyethelene, .190 ID x 7/16 inch OD
63	366-0113-00			1	KNOB, small charcoal—POSITION
	- - - - -			-	knob includes:
	213-0004-00			1	SCREW, set, 6-32 x 3/16 inch HSS
64	358-0054-00			1	BUSHING, banana jack
	- - - - -			-	mounting hardware: (not included w/bushing)
	210-0046-00			1	LOCKWASHER, internal, .400 OD x .261 inch ID
	210-0583-00			1	NUT, hex, 1/4-32 x 5/16 inch
65	384-0510-00			1	ROD, securing
	- - - - -			-	rod includes:
66	354-0025-00			1	RING, retaining
67	- - - - -			2	POT
68	- - - - -			-	mounting hardware for each: (not included w/pot)
	210-0471-00			1	NUT, pot, hex, 1/4-32 x 5/16 x 19/32 inch
	210-0046-00			1	LOCKWASHER, internal, .400 OD x .261 inch ID
69	358-0054-00			1	BUSHING, banana jack
70	- - - - -			1	POT
	- - - - -			-	mounting hardware: (not included w/pot)
	210-0012-00			1	LOCKWASHER, internal, 3/8 x 1/2 inch
	210-0840-00			1	WASHER, .390 ID x 7/16 inch OD
	210-0413-00			1	NUT, hex, 3/8-32 x 1/2 inch
71	384-0319-00			1	ROD, pot, extension
72	348-0055-00			2	GROMMET, plastic, 1/4 inch
73	- - - - -			1	POT
	- - - - -			-	mounting hardware: (not included w/pot)
	210-0046-00			1	LOCKWASHER, internal, .400 OD x .261 inch ID
	210-0562-00			1	NUT, hex, 1/4-40 x 5/16 inch
74	366-0128-00			1	KNOB, delrin—DC BAL
	- - - - -			-	knob includes:
	213-0076-00			1	SCREW, set, 2-56 x 1/8 inch HHS
75	407-0067-00			1	BRACKET, gusset
	- - - - -			-	mounting hardware: (not included w/bracket)
	211-0504-00			2	SCREW, 6-32 x 1/4 inch BHS
	211-0559-00			2	SCREW, 6-32 x 3/8 inch FHS phillips
	210-0457-00			2	NUT, keps, 6-32 x 5/16 inch

EXPLODED VIEW (Cont'd)

REF. NO.	PART NO.	SERIAL/MODEL NO.		QTY.	DESCRIPTION
		EFF.	DISC.		
76	179-931			1	CABLE HARNESS
77	124-145			5	STRIP, ceramic, $\frac{7}{16}$ inch x 20 notches
	- - - -			-	each strip includes:
	355-046			2	STUD, nylon
	- - - -			-	mounting hardware for each: (not included w/strip)
	361-009			2	SPACER, nylon, .313 inch
78	124-148			2	STRIP, ceramic, $\frac{7}{16}$ inch x 9 notches
	- - - -			-	each strip includes:
	355-046			2	STUD, nylon
	- - - -			-	mounting hardware for each: (not included w/strip)
	361-009			2	SPACER, nylon, .313 inch
79	- - - -			1	RESISTOR, 10 watt
	- - - -			-	mounting hardware: (not included w/resistor)
	211-553			1	SCREW, 6-32 x $1\frac{1}{2}$ inches RHS phillips
	210-601			1	EYELET
	210-478			1	NUT, hex, resistor mounting
	210-206			1	LUG, solder, SE #10 long
	211-507			1	SCREW, 6-32 x $\frac{5}{16}$ inch BHS
80	384-631			4	ROD, spacer, plug-in
81	- - - -			1	RESISTOR, 5 watt
	- - - -			-	mounting hardware: (not included w/resistor)
	211-544			1	SCREW, 6-32 x $\frac{3}{4}$ inch THS phillips
	210-478			1	NUT, hex, resistor mounting
	210-206			1	LUG, solder, SE #10 long
	211-507			1	SCREW, 6-32 x $\frac{5}{16}$ inch BHS
82	131-017			1	CONNECTOR, chassis mounted, 16 pin
	- - - -			-	mounting hardware: (not included w/connector)
	211-008			2	SCREW, 4-40 x $\frac{1}{4}$ inch BHS
	210-201			2	LUG, solder, SE #4
	210-406			2	NUT, hex, 4-40 x $\frac{3}{16}$ inch
83	387-980			1	PLATE, rear
	- - - -			-	mounting hardware: (not included w/plate)
84	212-044			4	SCREW, 8-32 x $\frac{1}{2}$ inch RHS phillips
85	210-201			3	LUG, solder, SE #4
	- - - -			-	mounting hardware for each: (not included w/lug)
	213-044			1	SCREW, thread cutting, 5-32 x $\frac{3}{16}$ inch PHS phillips
86	136-181			5	SOCKET, 3 pin transistor
	- - - -			-	mounting hardware for each: (not included w/socket)
87	354-234			1	RING, locking, transistor socket
88	136-014			3	SOCKET, STM9
	- - - -			-	mounting hardware for each: (not included w/socket)
	213-044			2	SCREW, thread cutting, 5-32 x $\frac{3}{16}$ inch PHS phillips

EXPLODED VIEW (Cont'd)

REF. NO.	PART NO.	SERIAL/MODEL NO.		QTY.	DESCRIPTION
		EFF.	DISC.		
89	136-0078-00 ----- 213-0055-00			1 - 2	SOCKET, 8 pin miniature - mounting hardware: (not included w/socket) 2 SCREW, thread cutting, 2-56 x 3/16 inch RHS phillips
90	441-0583-00 ----- 211-0504-00 211-0559-00 210-0457-00			1 - 2 2 2	CHASSIS, aluminum - mounting hardware: (not included w/chassis) 2 SCREW, 6-32 x 1/4 inch BHS 2 SCREW, 6-32 x 3/8 inch FHS phillips 2 NUT, keps, 6-32 x 5/16 inch
91	406-0399-00 ----- 211-0534-00			4 - 1	BRACKET, shockmount - mounting hardware for each: (not included w/bracket) 1 SCREW, 6-32 x 5/16 inch PHS w/lockwasher
92	348-0039-00 ----- 210-0006-00 210-0407-00			4 - 1 1	SHOCKMOUNT ASSEMBLY - mounting hardware for each: (not included w/shockmount) 1 LOCKWASHER, internal, #6 1 NUT, hex, 6-32 x 1/4 inch
93	407-0066-00			1	BRACKET, tube
94	136-0188-00			2	SOCKET, 5 pin
95	----- ----- 210-0840-00 210-0413-00			- - 1 1	POT - mounting hardware for each: (not included w/pot) 1 WASHER, .390 ID x 9/16 inch OD 1 NUT, hex, 3/8-32 x 1/2 inch
96	407-0064-00 ----- 211-0507-00 210-0457-00			1 - 2 2	BRACKET, pot - mounting hardware: (not included w/bracket) 2 SCREW, 6-32 x 5/16 inch BHS 2 NUT, keps, 6-32 x 5/16 inch
97	----- ----- 210-0207-00 210-0840-00 210-0413-00 210-0013-00			- - 1 1 1 1	POT - mounting hardware: (not included w/pot) 1 LUG, solder, 3/8 inch 1 WASHER, .390 ID x 9/16 inch OD 1 NUT, hex, 3/8-32 x 1/2 inch 1 LOCKWASHER, internal 3/8 x 1 1/16 inch
98	377-0103-00			2	INSERT, heat stailizer
99	200-0554-00 ----- 211-0517-00			1 - 1	COVER, heat stabilizer - mounting hardware: (not included w/cover) 1 SCREW, 6-32 x 7/8 inch BHS
100	348-0031-00	X1190		1	GROMMET, plastic, 3/32 inch
	070-0432-00			2	STANDARD ACCESSORIES MANUAL, instruction (not shown)

ELECTRICAL PARTS

Values are fixed unless marked Variable.

Ckt. No.	Tektronix Part No.		Description			S/N Range
Capacitors						
Tolerance $\pm 20\%$ unless otherwise indicated.						
C102†	Use *295-0094-00	0.1 μf	PTM		600 v	
C106B	281-102	1.7-11 pf	Air	Var		
C106C	281-102	1.7-11 pf	Air	Var		
C106D	283-109	27 pf	Cer		1000 v	5%
C106E	281-098	1.2-3.5 pf	Air	Var		
C106F	281-0613-00	10 pf	Cer		200 v	10% X870-up
C108B	281-103	1.8-13 pf	Air	Var		
C108C	281-098	1.2-3.5 pf	Air	Var		
C108D	281-613	10 pf	Cer		200 v	10% 100-869X
C108E	283-108	220 pf	Cer		200 v	10%
C109B	Use 281-0102-00	1.7-11 pf	Air	Var		
C109C	281-098	1.2-3.5 pf	Air	Var		
C109D	283-607	0.002 μf	Mica		500 v	10%
C110	281-099	1.3-5.4 pf	Air	Var		
C111	Use 283-0059-00	1 μf	Cer		25 v	+80%—20% X170-up
C113	281-063	9-35 pf	Cer	Var		
C114	283-000	0.001 μf	Cer		500 v	
C116	281-010	4.5-25 pf	Cer	Var		
C117	281-519	47 pf	Cer		500 v	10%
C166	281-534	3.3 pf	Cer		500 v	± 0.25 pf
C167	281-593	3.9 pf	Cer			10%
C174	281-005	1.5-7 pf	Cer	Var		
C177	281-601	7.5 pf	Cer		500 v	0.5 pf
C184	281-521	56 pf	Cer		500 v	10%
C190	283-001	0.005 μf	Cer		500 v	
C192	283-001	0.005 μf	Cer		500 v	
C195	283-001	0.005 μf	Cer		500 v	
C202†	Use *295-0094-00	0.1 μf	PTM		600	
C206B	281-102	1.7-11 pf	Air	Var		
C206C	281-102	1.7-11 pf	Air	Var		
C206D	283-109	27 pf	Cer		1000 v	5%
C206E	281-098	1.2-3.5 pf	Air	Var		
C206F	281-0613-00	10 pf	Cer		200 v	10% X870-up
C208B	281-103	1.8-13 pf	Air	Var		
C208C	281-098	1.2-3.5 pf	Air	Var		
C208D	281-613	10 pf	Cer		200 v	10% 100-869X
C208E	283-108	22 pf	Cer		200 v	10%
C209B	Use 281-0103-00	1.8-13 pf	Air	Var		
C209C	281-098	1.2-3.5 pf	Air	Var		
C209D	283-607	0.002 μf	Mica		500 v	10%
C210	281-099	1.3-5.4 pf	Air	Var		
C213	281-063	9-35 pf	Cer	Var		X170-up
C214	283-000	0.001 μf	Cer		500 v	

†C102 and C202 matched within $\pm 1\%$ of each other, furnished as a unit.

Parts List—Type W

Capacitors (Cont'd)

Ckt. No.	Tektronix Part No.	Description				S/N Range
C216	281-010	4.5-25 pf	Cer	Var		
C217	281-519	47 pf	Cer		500 v	10%
C274	281-005	1.5-7 pf	Cer	Var		
C283	283-057	0.1 μ f	Cer		200 v	X170-up
C284	281-060	2-8 pf	Cer	Var		
C286	285-555	0.1 pf	PTM		100 v	

Diodes

D113	*152-165	Silicon	Selected from 1N3579			
D142A,B	*152-178	Silicon	Tek Spec			
D175	152-147	Zener	1N971B 0.4 w, 27 v, 5%			
D193	152-172	Zener	1N970A 0.4 w, 24 v, 10%			
D213	*152-165	Silicon	Selected from 1N3579			
D301	*152-171	Zener	Selected 1N944 11.7 v, 5%			

Inductors

LR106B	*108-299	0.25 μ h (wound on a 62 Ω resistor)				100-869
LR106B	*108-0332-00	0.75 μ h (wound on a 130 Ω resistor)				870-up
LR106D	*108-299	0.25 μ h (wound on a 62 Ω resistor)				100-869X
LR106G	*108-0270-00	0.25 μ h (wound on a 62 Ω resistor)				X870-up
LR108B	*108-298	0.25 μ h (wound on a 36 Ω resistor)				
LR108D	*108-0271-00	0.25 μ h (wound on a 51 Ω resistor)				X870-up
LR206B	*108-299	0.25 μ h (wound on a 62 Ω resistor)				100-869
LR206B	*108-0332-00	0.75 μ h (wound on a 130 Ω resistor)				870-up
LR206D	*108-299	0.25 μ h (wound on a 62 Ω resistor)				100-869X
LR206G	*108-0270-00	0.25 μ h (wound on a 62 Ω resistor)				X870-up
LR208B	*108-298	0.25 μ h (wound on a 36 Ω resistor)				
LR208D	*108-0271-00	0.25 μ h (wound on a 51 Ω resistor)				X870-up

Transformers

T150	276-541	Ferrite Core
T155	276-541	Ferrite Core

Transistors

Q134	*151-103	Replaceable by 2N2219
Q154	*151-139	Dual, Selected from 2N918's
Q174	*151-133	Selected from 2N3251
Q184	*151-120	Selected from 2N2475
Q274	*151-133	Selected from 2N3251
Q284	*151-120	Selected from 2N2475

Resistors

Resistors are fixed, composition, $\pm 10\%$ unless otherwise indicated.

R105A	323-680	988 k	$\frac{1}{2}$ w		Prec	1%
R105B	311-487	30 k		Var		

Resistors (Cont'd)

Ckt. No.	Tektronix Part No.		Description			S/N Range
R106A†	325-004	900 k	1/4 w		Prec	1/10%
R106C††	325-003	99.8 k	1/8 w		Prec	1/10%
R106E	311-486	500 Ω		Var		
R106F	316-0101-00	100 Ω	1/4 w			X870-up
R108A	323-681	990 k	1/2 w		Prec	1%
R108D	316-101	100 Ω	1/4 w			100-869X
R108F	321-637	9.9 k	1/8 w		Prec	1/2%
R108G	311-485	250 Ω		Var		
R109A	323-623	999 k	1/2 w		Prec	1%
R109B	316-101	100 Ω	1/4 w			
R109D	316-470	47 Ω	1/4 w			
R109F	321-193	1 k	1/8 w		Prec	1%
R110	315-271	270 Ω	1/4 w			5%
R111	302-470	47 Ω	1/2 w			
R113	315-202	2 k	1/4 w			5%
R116	316-101	100 Ω	1/4 w			X170-up
R118	323-366	63.4 k	1/2 w		Prec	1%
R119	323-469	750 k	1/2 w		Prec	1%
R122	323-281	8.25 k	1/2 w		Prec	1%
R124	316-101	100 Ω	1/4 w			
R126	323-302	13.7 k	1/2 w		Prec	1%
R127	311-091	1 k		Var		DC BAL
R128	323-302	13.7 k	1/2 w		Prec	1%
R130	316-101	100 Ω	1/4 w			
R133	308-313	20 k	3 w		WW	1%
R134	323-278	7.68 k	1/2 w		Prec	1%
R136	316-470	47 Ω	1/4 w			
R139	324-605	3.33 k	1 w		Prec	1%
R143	323-360	54.9 k	1/2 w		Prec	1%
R144	323-348	41.2 k	1/2 w		Prec	1%
R144	321-405	162 k	1/8 w		Prec	1%
R149	323-210	1.5 k	1/2 w		Prec	1%
R150	315-820	82 Ω	1/4 w			5%
R152	316-101	100 Ω	1/4 w			
R154	321-091	86.6 Ω	1/8 w		Prec	1%
R155†††	311-422	500 Ω		Var		VARIABLE (MV/CM)
R157	311-169	100 Ω		Var		GAIN
R158	321-091	86.6 Ω	1/8 w		Prec	1%
R160	323-318	20 k	1/2 w		Prec	1%
R161	311-086	2.5 k		Var		VAR BAL
R163	323-318	20 k	1/2 w		Prec	1%
R165	323-239	3.01 k	1/2 w		Prec	1%
R166	323-181	750 Ω	1/2 w		Prec	1%
R167	323-147	332 Ω	1/2 w		Prec	1%
R168	323-116	158 Ω	1/2 w		Prec	1%
R169	323-647	61.4 Ω	1/2 w		Prec	1%
R172	323-197	1.1 k	1/2 w		Prec	1%
R173	316-470	47 Ω	1/4 w			
R174	323-201	1.21 k	1/2 w		Prec	1%
R175	323-201	1.21 k	1/2 w		Prec	1%
R175	322-0654-00	920 Ω	1/4 w		Prec	1%

†R106A and R206A furnished as a unit.

††R106C and R206C furnished as a unit.

†††Furnished as a unit with SW155.

Parts List—Type W

Resistors (Cont'd)

Ckt. No.	Tektronix Part No.		Description			S/N Range
R176	311-181	250 Ω		Var		POSITION RANGE
R177	315-331	330 Ω	1/4 w			5%
R178	308-286	8.2 k	3 w		WW	5%
R179	321-145	316 Ω	1/8 w		Prec	1%
R184	323-066	47.5 Ω	1/2 w		Prec	1%
R190	302-470	47 Ω	1/2 w			
R192	302-470	47 Ω	1/2 w			
R193	304-273	27 k	1 w			
R195	302-470	47 Ω	1/2 w			
R205A	323-680	988 k	1/2 w		Prec	1%
R205B	311-487	30 k		Var		
R206A†	325-004	900 k	1/4 w		Prec	1/10%
R206C††	325-003	99.8 k	1/8 w		Prec	1/10%
R206E	311-486	500 Ω		Var		
R206F	316-0101-00	100 Ω	1/4 w			X870-up
R208A	323-681	990 k	1/2 w		Prec	1/2%
R208D	316-101	100 Ω	1/4 w			100-869X
R208F	321-637	9.9 k	1/8 w		Prec	1/2%
R208G	311-485	250 Ω		Var		
R209A	323-623	999 k	1/2 w		Prec	1%
R209B	316-101	100 Ω	1/4 w			
R209D	316-470	47 Ω	1/4 w			
R209F	321-193	1 k	1/8 w		Prec	1%
R210	315-271	270 Ω	1/4 w			5%
R213	315-202	2 k	1/4 w			5%
R216	316-101	100 Ω	1/4 w			X170-up
R218	323-366	63.4 k	1/2 w		Prec	1%
R219	323-469	750 k	1/2 w		Prec	1%
R222	323-281	8.25 k	1/2 w		Prec	1%
R223	311-329	50 k		Var		DIFF BAL
R243	323-360	54.9 k	1/2 w		Prec	1%
R244	323-348	41.2 k	1/2 w		Prec	1%
R244	321-405	162 k	1/8 w		Prec	1%
R249	323-210	1.5 k	1/2 w		Prec	1%
R250	315-820	82 Ω	1/4 w			5%
R252	316-101	100 Ω	1/4 w			
R272	323-197	1.1 k	1/2 w		Prec	1%
R273	316-470	47 Ω	1/4 w			
R274	323-201	1.21 k	1/2 w		Prec	1%
R278	308-286	8.2 k	3 w		WW	5%
R279	311-362	500 Ω		Var		POSITION
R280	311-474	2 k		Var	WW	DC LEVEL
R281	323-166	523 Ω	1/2 w		Prec	1%
R282	301-303	30 k	1/2 w			5%
R282	301-0103-00	10 k	1/2 w			5%
R283	308-003	2 k	5 w		WW	5%
R284	323-066	47.5 Ω	1/2 w		Prec	1%
R286	308-071	500 Ω	5 w		WW	5%
R390	308-315	150 Ω	10 w		WW	5%

†R206A and R106A furnished as a unit.

††R206C and R106C furnished as a unit.

Resistors (Cont'd)

Ckt. No.	Tektronix Part No.		Description			S/N Range
R292	305-750	75 Ω	2 w			5%
R293	311-473	100 Ω		Var	WW	HEATER BAL
R295	305-750	75 Ω	2 w			5%
R301	308-321	24.4 k	5 w		WW	1%
R303	308-320	15.6 k	3 w		WW	1%
R306	301-113	11 k	1/2 w			5%
R308	308-330	300 Ω	1/2 w		WW	1% (Selected)
R310	311-484	500 Ω		Var		Vc CAL
R313	308-326	9.9 k	1/2 w		WW	0.01 %
R315	308-324	1.222 k	1/2 w		WW	0.01 %
R322	308-316	3.1 k	5 w		WW	1%
R323	311-484	500 Ω		Var		TRACKING
R325†	311-360	5 k		Var		VARIABLE Vc
R327	302-102	1 k	1/2 w			
R330	} †† 308-323	1 k	1/4 w		WW	
thru						
R341						

Switches

	Unwired	Wired			
SW101	260-603		Rotary		AC-DC-GND A
SW105††† } SW205 }	260-634	*262-680	Rotary		INPUT ATTENUATOR 100-869
SW105 } SW205 }	260-0634-00	262-0680-01	Rotary		INPUT ATTENUATOR 870-up
SW110††††	260-635	*262-679	Rotary		DISPLAY
SW150	260-632	*262-676	Rotary		MILLIVOLTS/CM
SW155†††††	311-422				CALIB
SW201	260-603		Rotary		AC-DC-GND B
SW310	260-633	*262-678	Rotary		Vc RANGE
SW320†††††† Use	*050-0263-00	*262-677	Rotary		COM VOLTAGE (Vc) 100-1629
SW320††††††	260-0777-00	*262-0677-00	Rotary		COM VOLTAGE (Vc) 1630-up

Electron Tubes

V113††††††††	*157-099	8056, checked
V114	154-413	8416
V124	154-413	8416
V213††††††††	*157-099	8056, checked
V214	154-413	8416

†Concentric with SW320.

††Matched within ±0.02% of each other.

†††SW105 and SW205 furnished as a unit.

††††SW110 concentric with SW105 and SW205.

†††††SW155 furnished as a unit with R155.

††††††SW320 concentric with R325.

†††††††V113 and V213 furnished as a unit.

IMPORTANT:

Circuit voltages were obtained with a 20,000 Ω /Volt VOM. All readings are in volts.

Voltage and waveform amplitude measurements are not absolute and may vary from unit to unit. For these measurements, a 30" flexible cable plug-in extension (012-038) was used to operate the W Unit out of the oscilloscope plug-in compartment.

Actual waveform photographs are shown with the test oscilloscope set for +Ext triggering on the same signal applied to the W Unit.

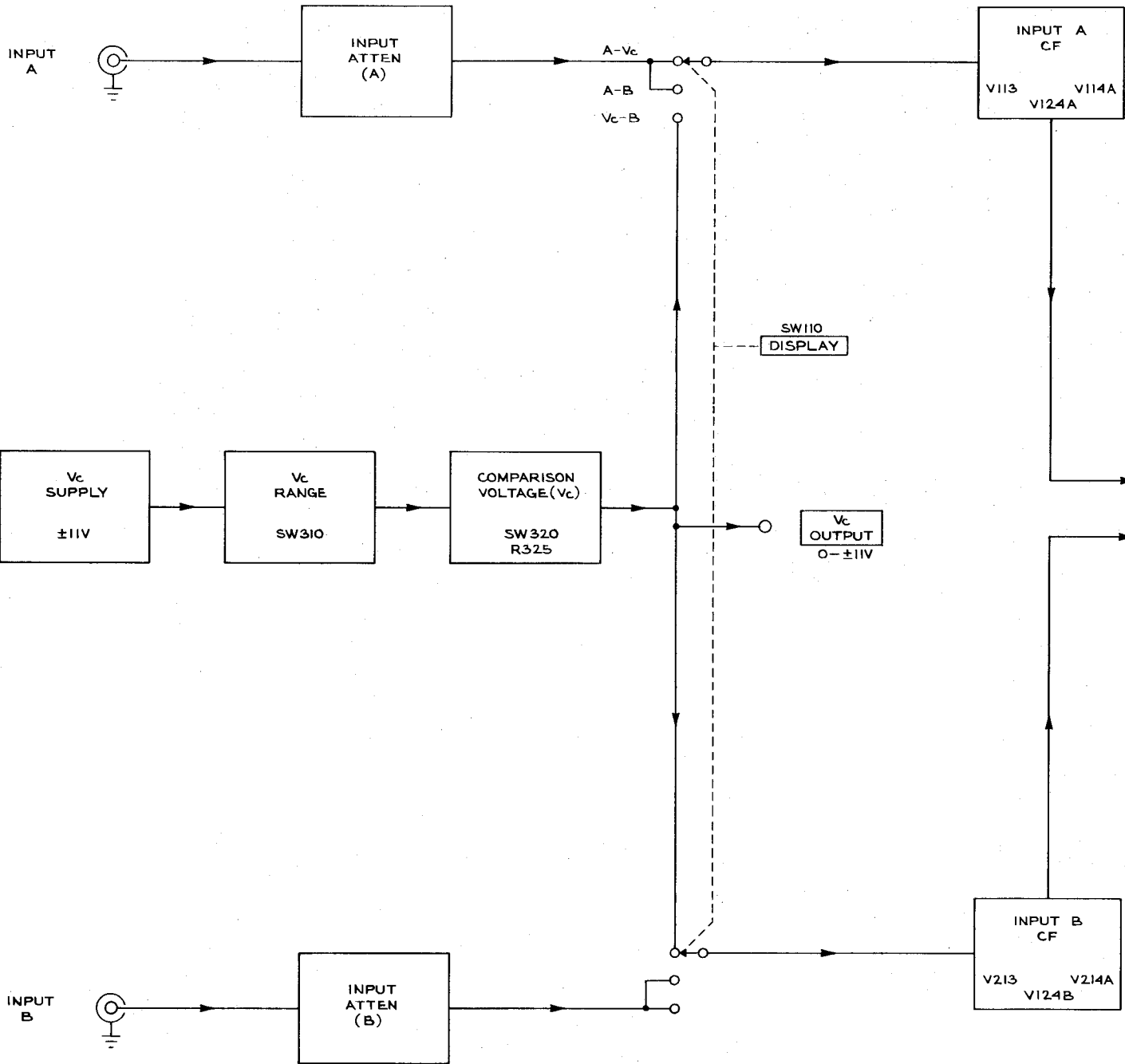

TYPE W PLUG-IN

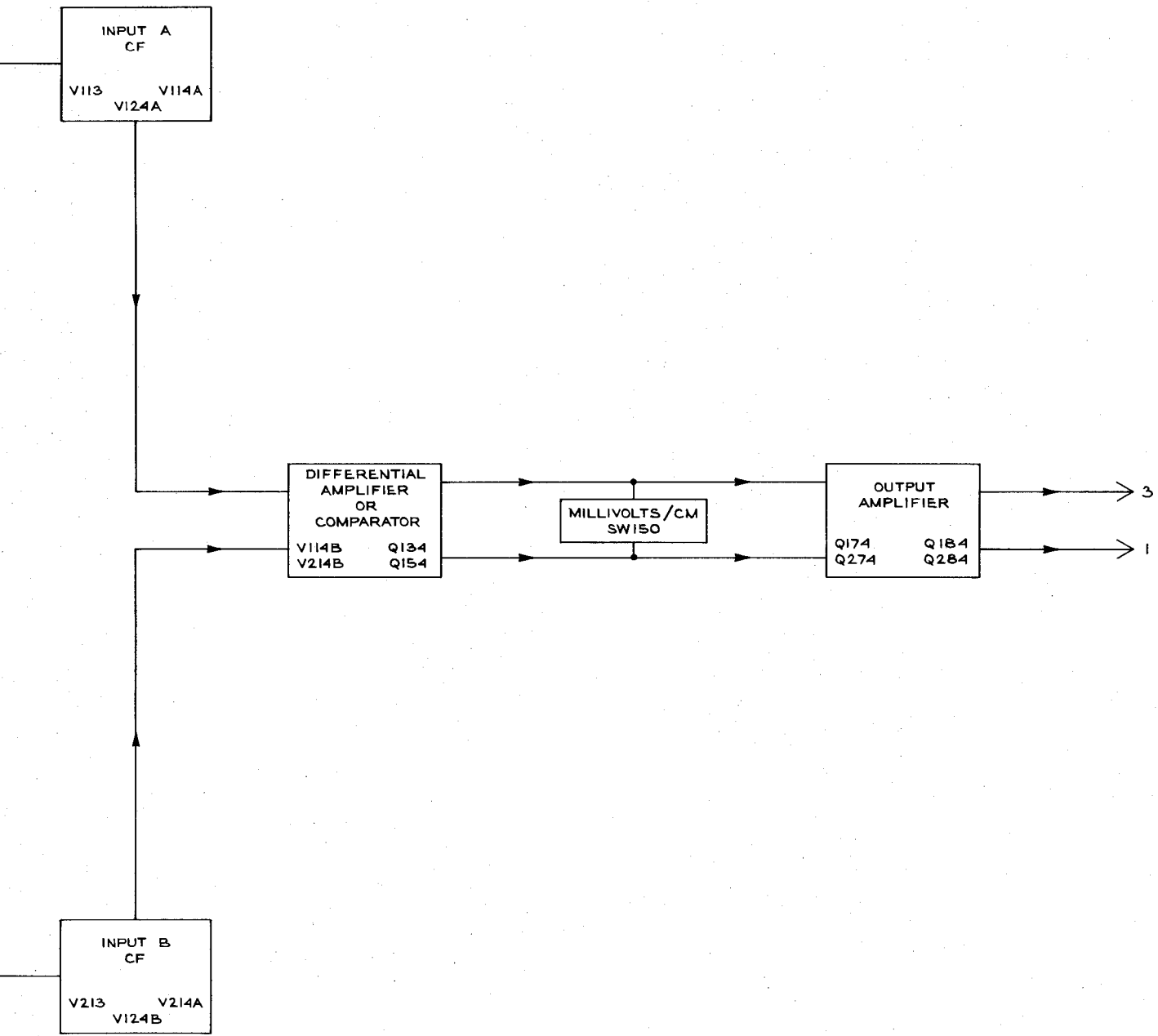

CMP
964

A

BLOCK DIAGRAM

VOLTAGE AND WAVEFORM READINGS were obtained under the following common conditions:

Vc RANGE	+11
COMPARISON VOLTAGE	11 (10-10-0)
AC-DC-GND (Channel A)	DC
AC-DC-GND (Channel B)	GND
INPUT ATTEN	10
DISPLAY	A-B
MILLIVOLTS/CM	50
VARIABLE	CALIB
POSITION	Centered

QUIESCENT VOLTAGE READINGS:

Input signal to channel A	None
---------------------------	------

WAVEFORMS:

Input signal to channel A	2-Volt 1-kc Oscilloscope Calibrator Signal
---------------------------	--

VOLTAGE & WAVEFORM
CONDITIONS
(SEE IMPORTANT NOTE
ON BLOCK DIAGRAM)

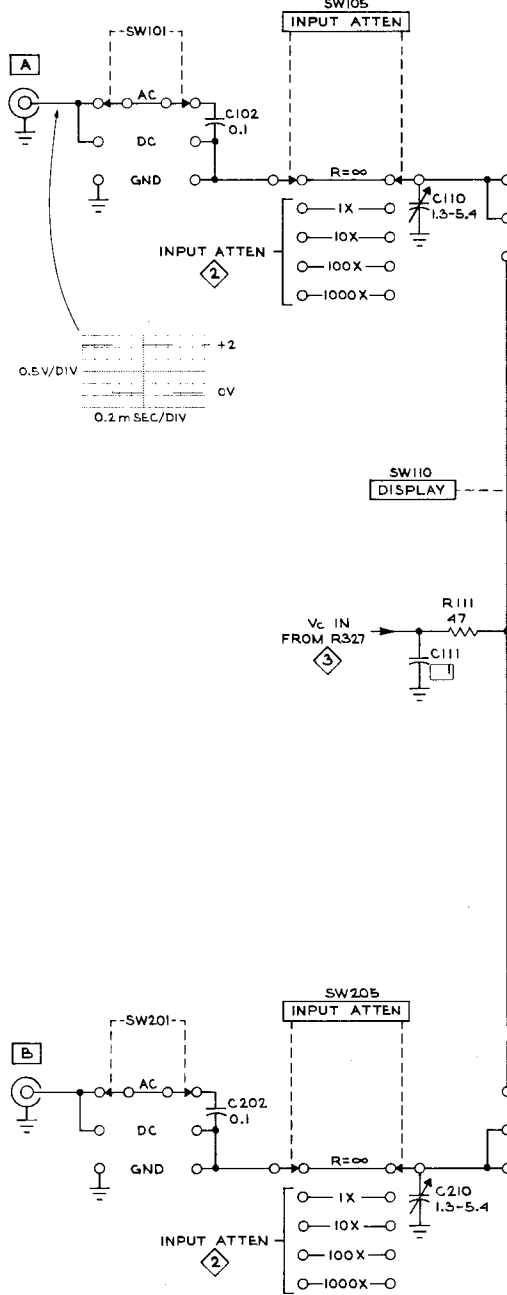

REFERENCE DIAGRAMS

- ② INPUT ATTENUATORS
- ③ SWITCHING DIAGRAM

TYPE W PLUG-IN

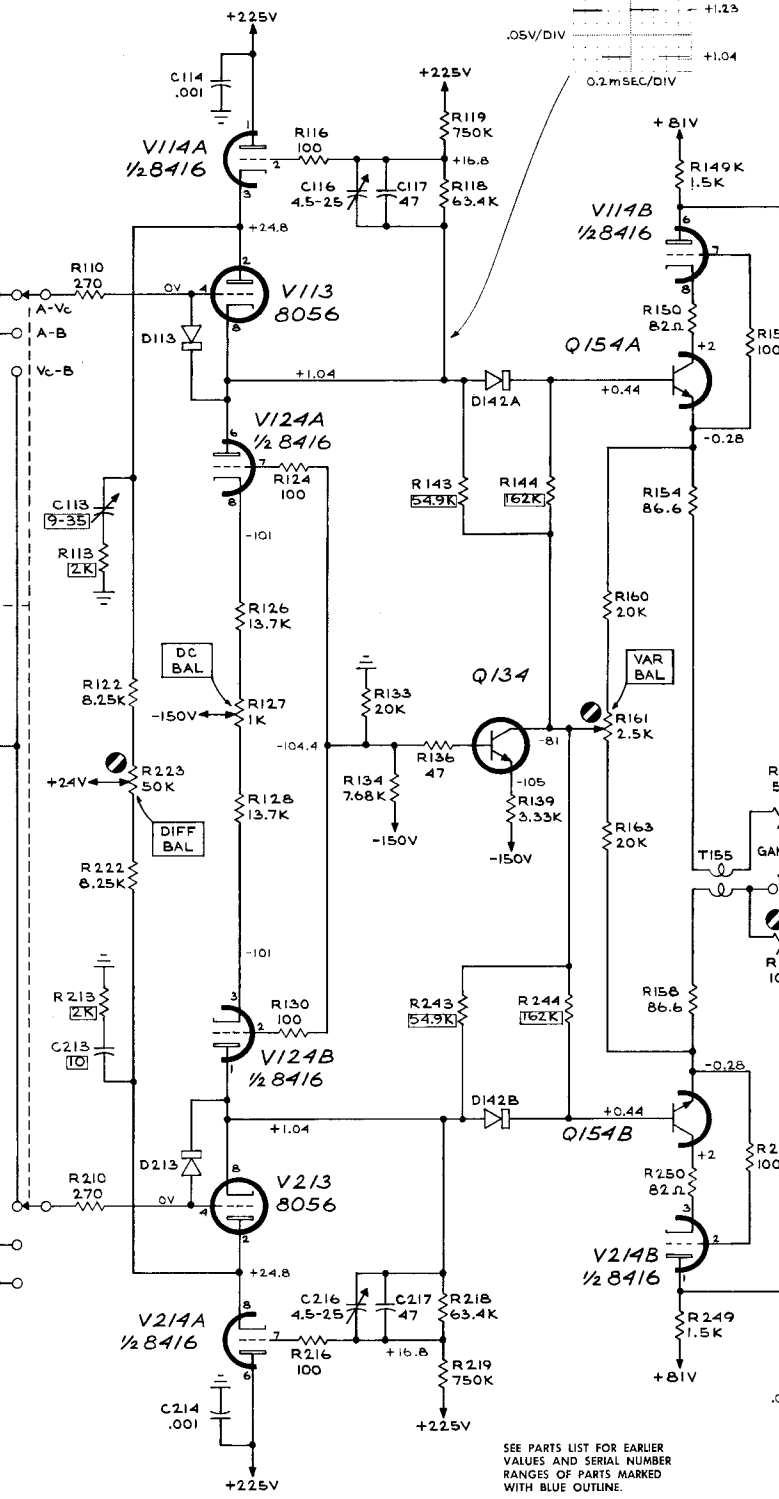

SEE PARTS LIST FOR EARLIER
VALUES AND SERIAL NUMBER
RANGES OF PARTS MARKED
WITH BLUE OUTLINE.

SEE PARTS LIST FOR
SEMICONDUCTOR TYPES

+

F1

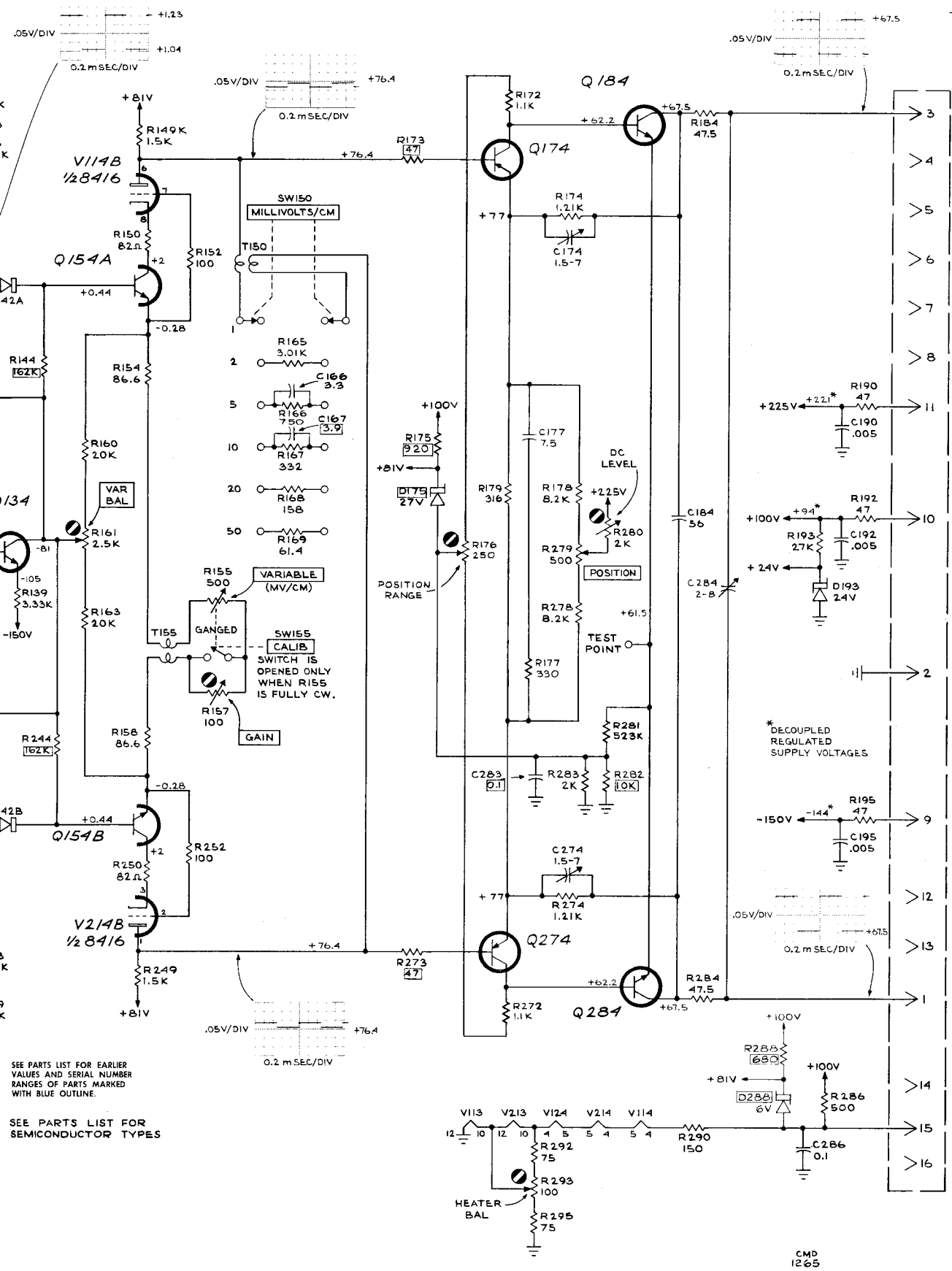

SEE PARTS LIST FOR EARLIER VALUES AND SERIAL NUMBER RANGES OF PARTS MARKED WITH BLUE OUTLINE.

SEE PARTS LIST FOR SEMICONDUCTOR TYPES

* DECOUPLED REGULATED SUPPLY VOLTAGES

CMD 1265

HIGH-GAIN DIFFERENTIAL COMPARATOR



INPUT A

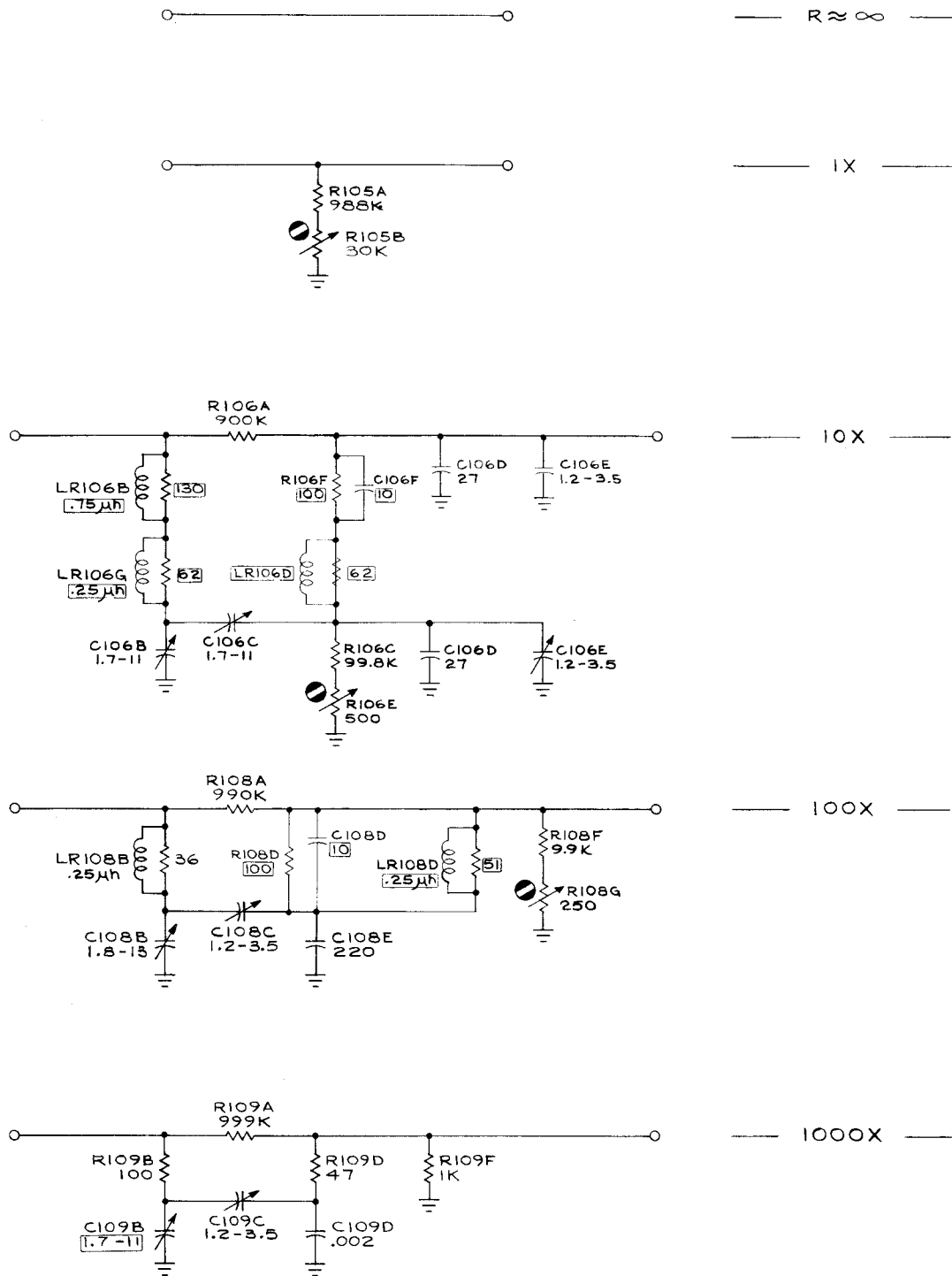

SEE PARTS LIST FOR EARLIER VALUES AND SERIAL NUMBER RANGES OF PARTS MARKED WITH BLUE OUTLINE.

TYPE W PLUG-IN

C

+

INPUT B

— R ≈ ∞ —

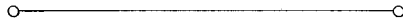

— IX —

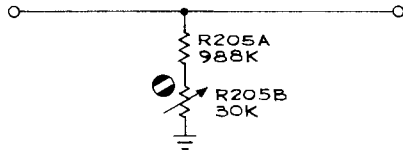

— 10X —

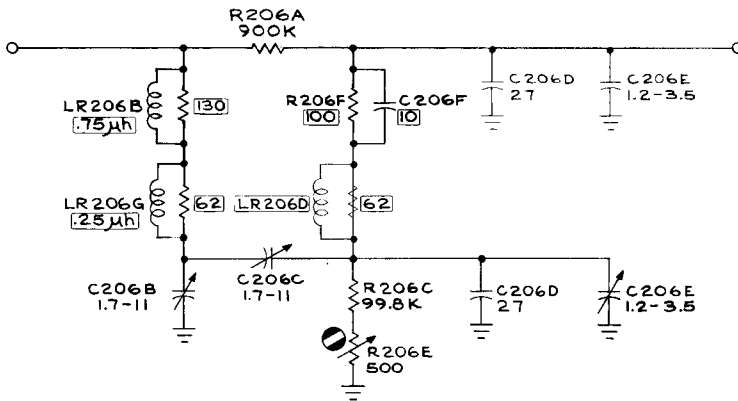

— 100X —

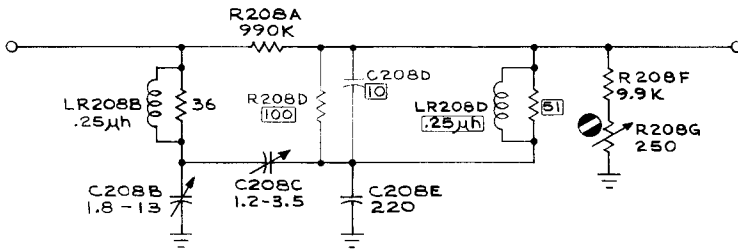

— 1000X —

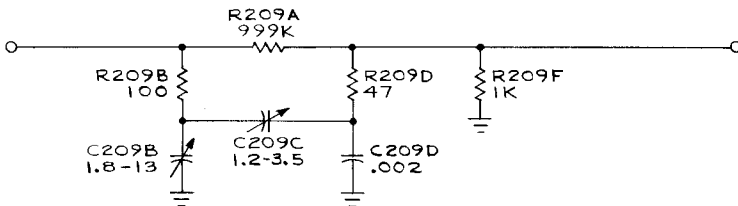

SEE PARTS LIST FOR EARLIER VALUES AND SERIAL NUMBER RANGES OF PARTS MARKED WITH BLUE OUTLINE.

MRH
466

VOLTAGE READINGS were obtained under the following conditions:

V _c RANGE	+ 11
COMPARISON VOLTAGE	10.00

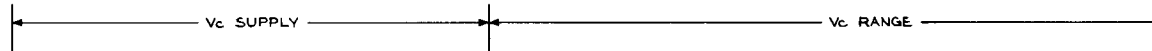

← VOLTAGE & WAVEFORM
 CONDITIONS
 (SEE IMPORTANT NOTE ON
 BLOCK DIAGRAM PAGE)

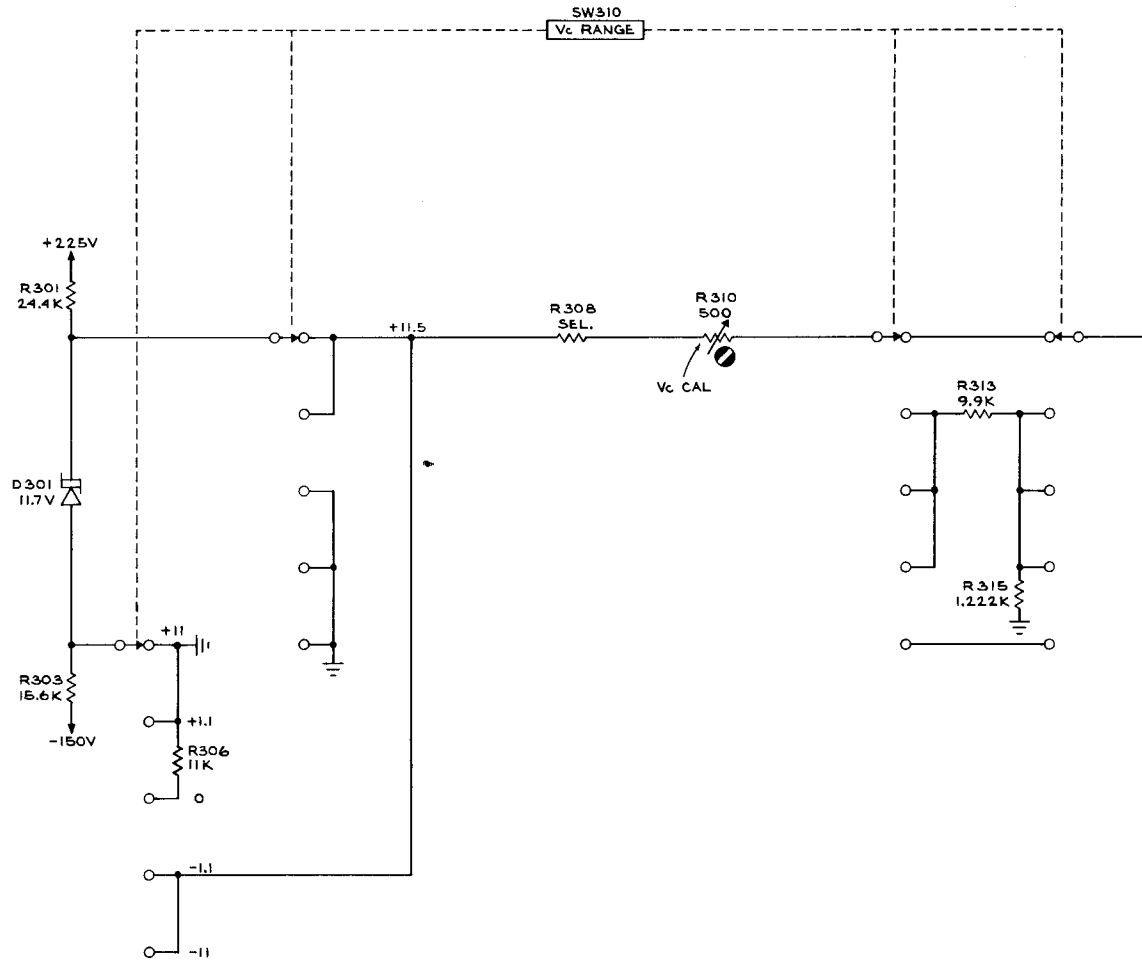

REFERENCE DIAGRAMS

HIGH-GAIN DIFFERENTIAL COMPARATOR

TYPE W PLUG-IN

+

A₁

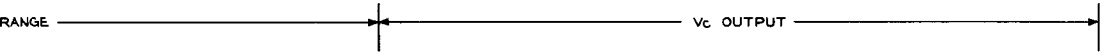

+

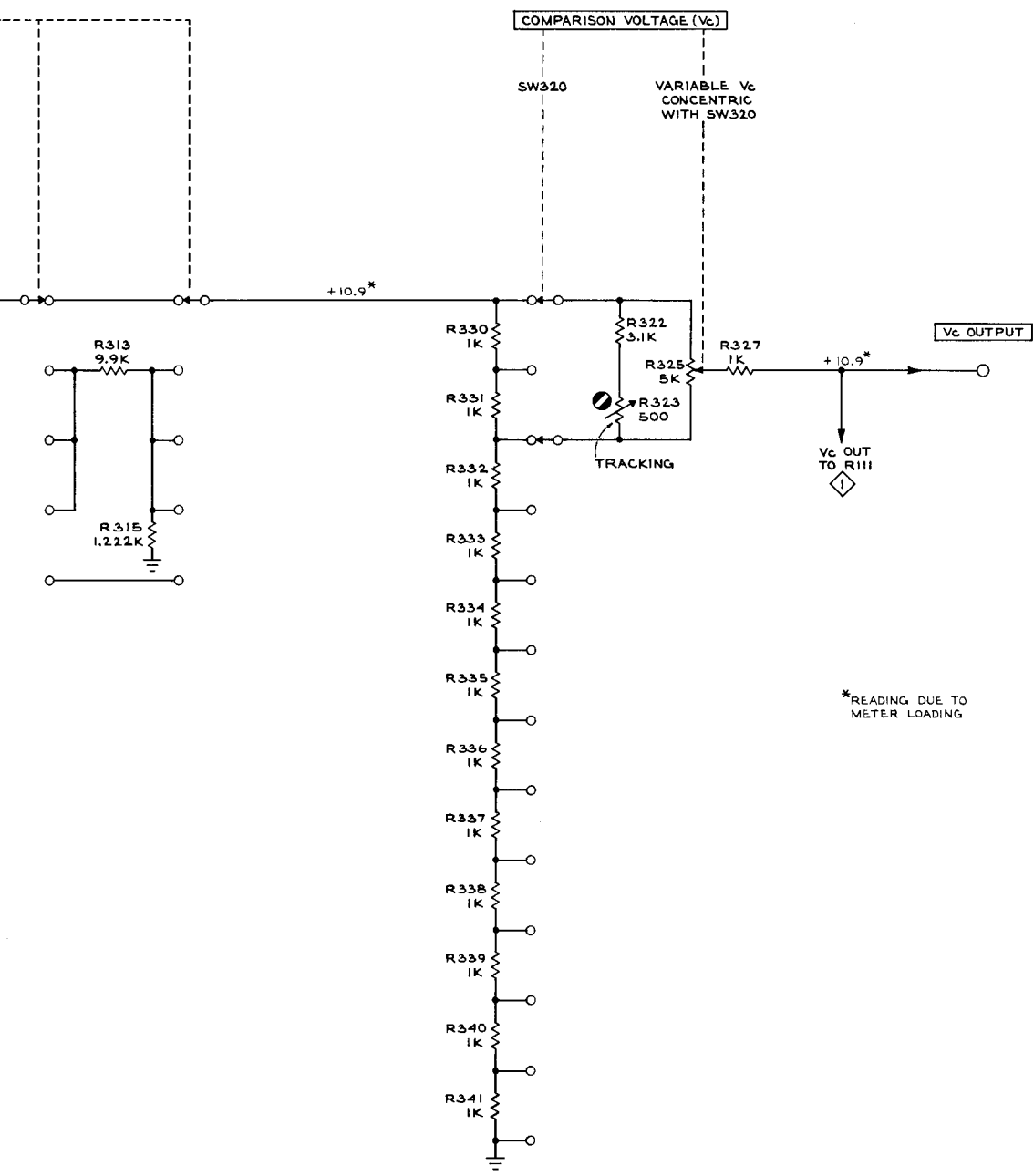

*READING DUE TO METER LOADING

CMB
964

A₁

SWITCHING DIAGRAM

3

MANUAL CHANGE INFORMATION

At Tektronix, we continually strive to keep up with latest electronic developments by adding circuit and component improvements to our instruments as soon as they are developed and tested.

Sometimes, due to printing and shipping requirements, we can't get these changes immediately into printed manuals. Hence, your manual may contain new change information on following pages. If it does not, your manual is correct as printed.

TYPE W TENT SN 2530

PARTS LIST CORRECTION

CHANGE TO:

R155/SW155

311-0630-00

500 Ω

1/4 W

10%

Var

TEXT CORRECTION

Section 5 Calibration

The following procedure replaces steps 21-h through 23-a on pages 5-8 and 5-9 in the Calibration section:

21-

h. Disconnect all jumper leads including the jumper clip-lead that connects from the A-input connector to the junction of R310 and the wiper contact of SW310. Disconnect the binding-post connector adapter from the A-input connector.

22. Check Input A 1000X Attenuator

a. Set the INPUT ATTEN switch to 1. Check that the DISPLAY switch is set to A-Vc and the MILLIVOLTS/CM switch is set to 1.

b. Apply a 5-mv peak-to-peak amplitude calibrator signal through a coaxial cable to the A-input connector. Set the oscilloscope triggering controls to obtain a stable display.

c. Note the amplitude of the display because this will be used as a reference when checking the display amplitude in step 22-f.

d. Set the INPUT ATTEN switch to 1000.

e. Set the Amplitude Calibrator switch to 5 Volts.

f. Check that the amplitude of the display is within ± 1.5 mm ($\pm 3\%$) of the display amplitude noted in step 22-c. (Take into consideration the accuracy of the signal source when performing steps 22-c and 22-f).

g. Disconnect the calibrator signal.

h. Free run the trace. Position the trace to graticule center.

23. Adjust R105B (Input A 1X Attenuator)

a. Connect a binding-post connector to the A input connector. Connect one end of a 1-meg (1%) resistor to the connector adapter. Connect a short clip-lead jumper from the other end of the resistor to the junction of R310 and the wiper contact of SW310 (see Fig. 5-1).

The following procedure replaces steps 25-f through 27-a on page 5-9 in the Calibration section:

TYPE W

25-

f. Disconnect all jumper leads including the jumper clip-lead that connects from the A-input connector to the junction of R310 and the wiper contact of SW310. Disconnect the binding-post connector adapter from the B-input connector.

26. Check Input B 1000X Attenuator

a. Set the INPUT ATTEN switch to 1. Check that the DISPLAY switch is set to Vc-B and the MILLIVOLTS/CM switch is set to 1.

b. Apply a 5-mv peak-to-peak amplitude calibrator signal through a coaxial cable to the B-input connector. Set the oscilloscope triggering controls to obtain a stable display.

c. Note the amplitude of the display because this will be used as a reference.

d. Set the INPUT ATTEN switch to 1000.

e. Set the Amplitude Calibrator switch to 5 Volts.

f. Check that the amplitude of the display is within ± 1.5 mm ($\pm 3\%$) of the display amplitude noted in step 26-c. (Consider the accuracy of the signal source when performing steps 26-c and 26-f).

g. Disconnect the calibrator signal.

h. Free run the trace and position the trace to graticule center.

27. Adjust R205B (Input B 1X Attenuator)

a. Connect a binding-post connector adapter to the B-input connector. Connect one end of a 1-meg (1%) resistor to the connector adapter. Connect a short clip-lead jumper from the other end of the resistor to the junction of R310 and the Wiper contact of SW310 (see Fig. 5-1).